

Vector Frame Counter 04

VFC-04

Vector Frame™ counters compliment the Vector Frame series of exhibit kits, but are also ideal for any stand-alone event or display. Vector Frame counters couple simple extrusion-based frames with push-fit graphics. Countertops are available in four colored finishes. Custom sizes also available.



features and benefits:

- Feature push-fit fabric graphics and simple extrusion based frames
- Choose from four countertop finishes
- Easy step-by-step instructions
- Wheeled portable shipping case
- Lifetime limited warranty against manufacturer defects

dimensions:

Hardware	Graphic
Assembled unit: 31" w x 40.5" h x 19" d 1400mm(w) x 1029mm(h) x 572mm(d)	Refer to related graphic template for more information
Approximate unit weight: 52 lbs / 24 kg	Visit: https://www.theexhibitorshandbook.com/download-graphic-templates

Shipping

Packing case(s)
1 OCH2

Shipping dimensions:
52" l x 29" h x 15" d
1321mm(l) x 737mm(h) x 381mm(d)

Approximate shipping weight:
82 lbs / 37 kg

additional information:

Graphic material:
Dye-sublimation SEG push-fit fabric

Counter holds max weight
100 lbs / 46 kg

Tabletop Colors:



silver



black



mahogany



natural



This product may include the following materials for recycle:
aluminum, select wood, fabric, cardboard, paper, steel, and plastics.

We are continually improving and modifying our product range and reserve the right to vary the specifications without prior notice. All dimensions and weights quoted are approximate and we accept no responsibility for variance. E&OE. See Graphic Templates for graphic bleed specifications.

Included In Your Kit

Tools, Components, & Connectors



5MM ALLEN-T x1



CB10-R x8



PMFC2-90-CAP x4



PMFC2-90-986-L1-L1 x2



PHFC2-600-L-L x2



PHFC2-300-L-L x4



TUBE-30-910 x4



PHFC2-100-L-L x4



VFC-04-INT-SHLF x1



VFC-04-CT x1



PE-1000 x2



PH1-288-L-L x4

Graphics

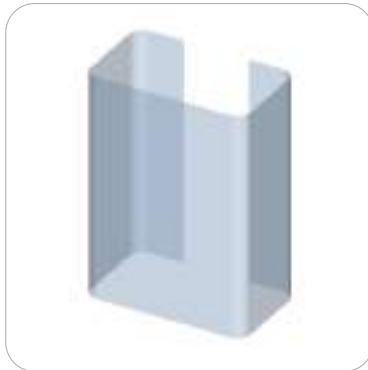

VFC-04-A-G x1

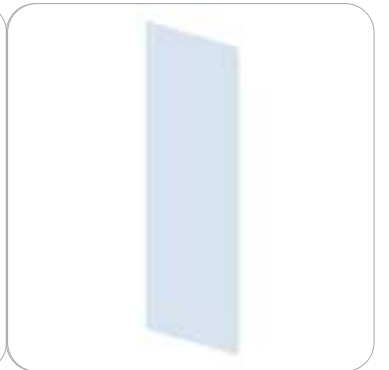

VFC-04-B-G x1

Exploded View

VFC-04
Section 1

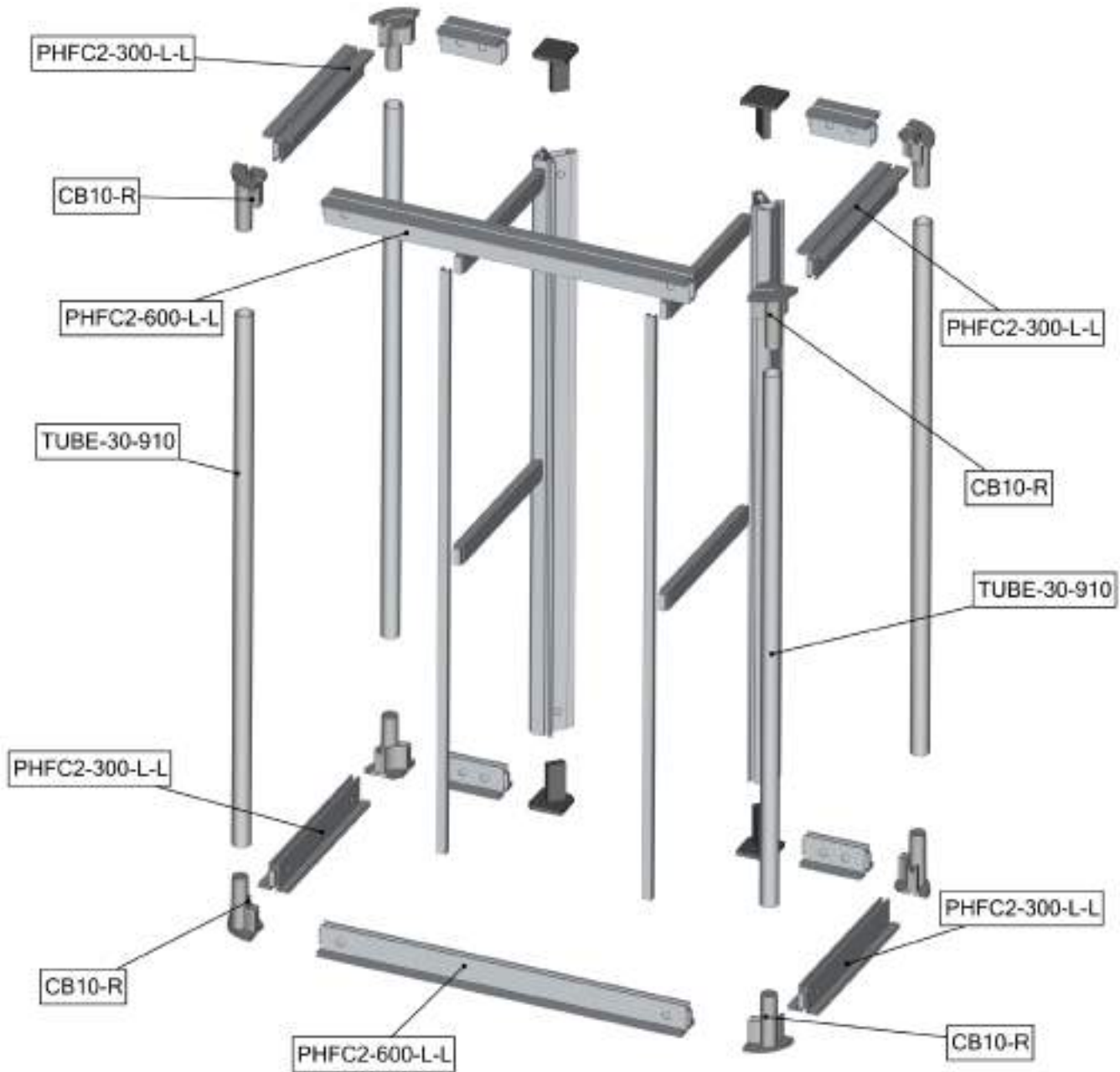

Exploded View

VFC-04
Section 2

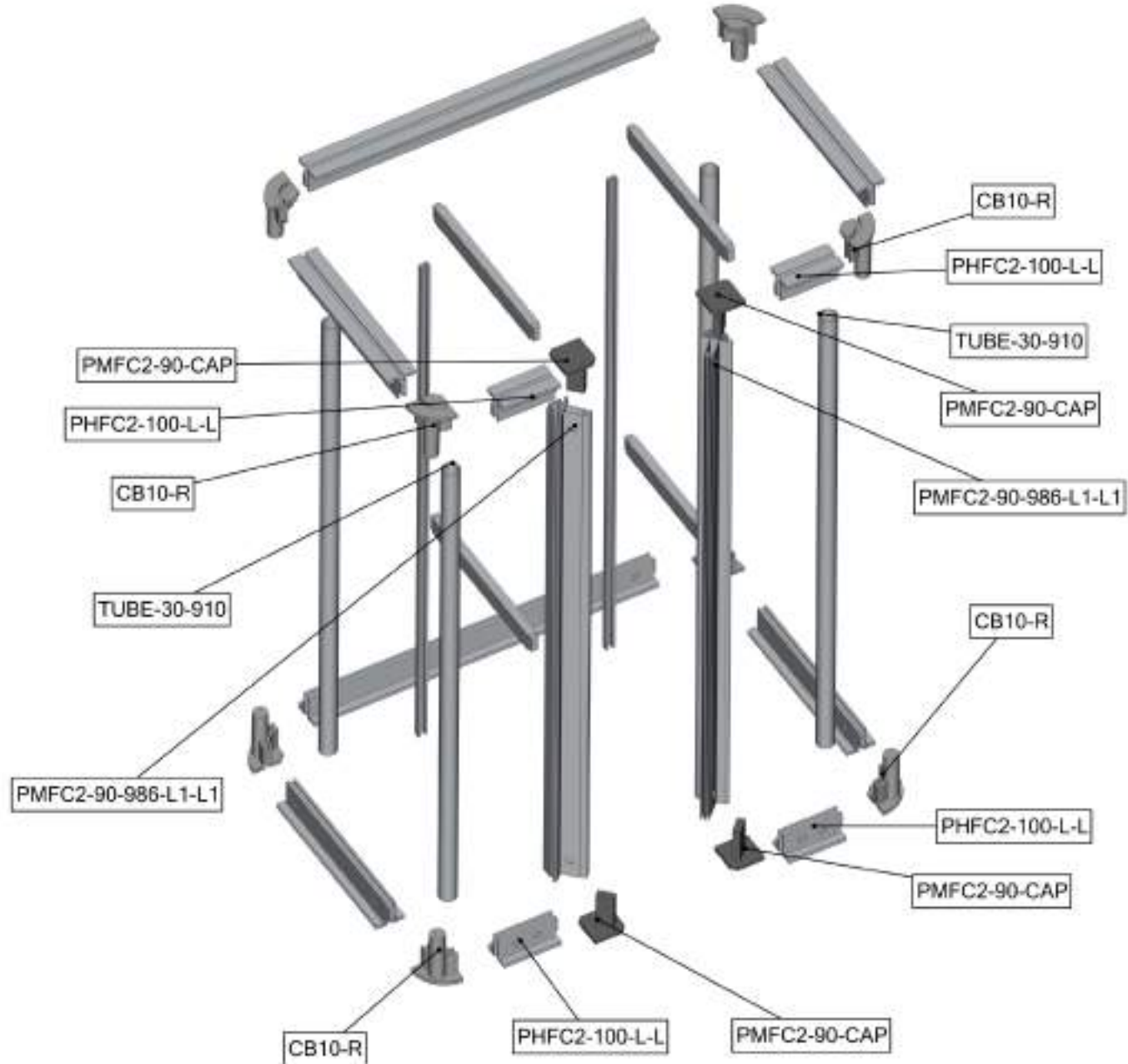

Exploded View

VFC-04
Section 3

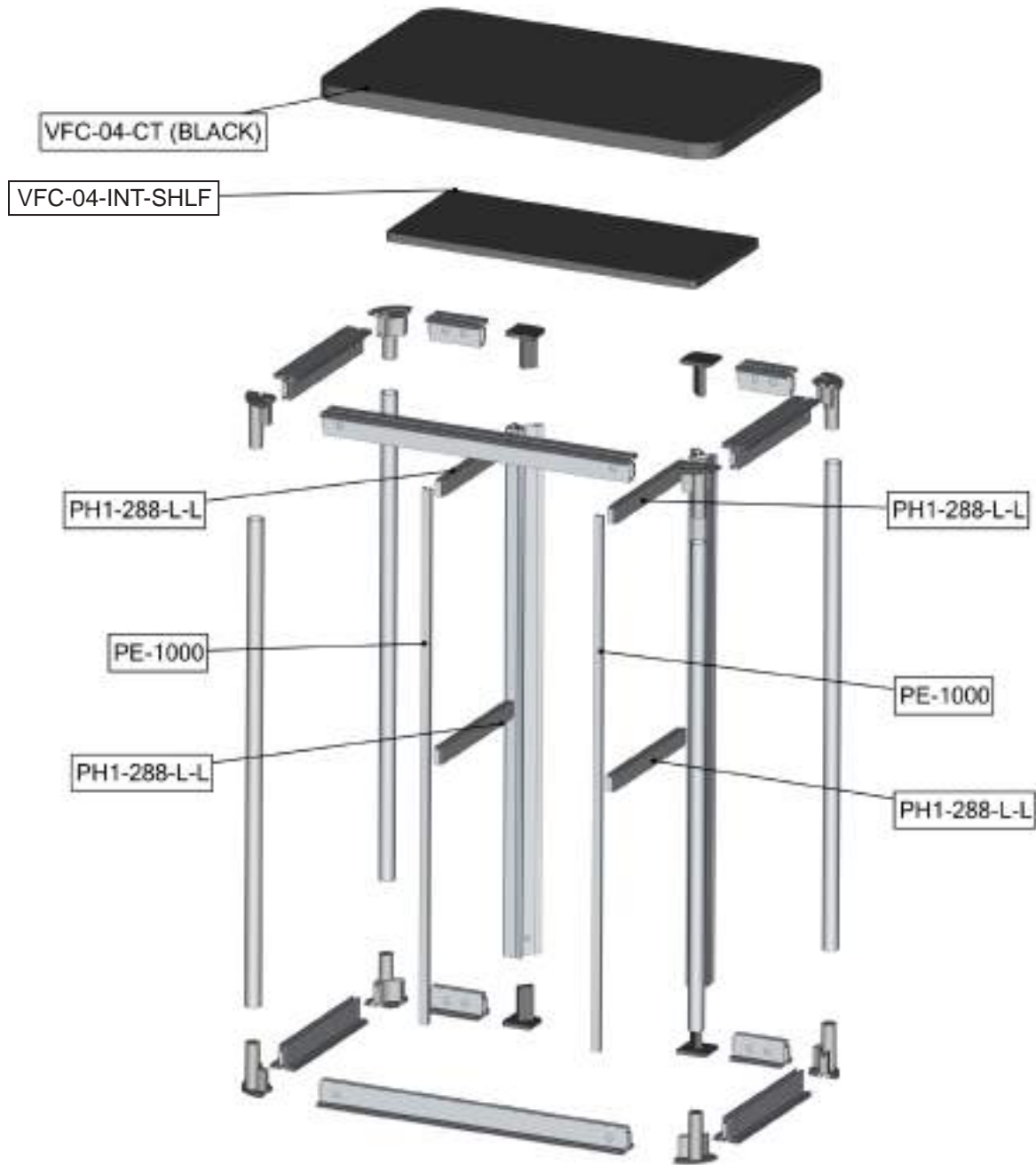

Kit Assembly

Step by Step

Step 1.

Gather the components to build the counter frame sections 1 and 2. Use the Exploded View section 1 and 2 for part labels.

Reference Connection Method(s) 1, 2 and 3 for more details.



Step 2.

Gather the components to build the counter frame section 3. Use the Exploded View section 3 for part labels. Use section 3 to merge sections 1 and 2.

Reference Connection Method(s) 2, 3 and 4 for more details.



Step 3.

Apply the counter fabric graphics by pressing the edges of the graphic into the extrusion fabric channel.

Reference Connection Method 5 for more details.

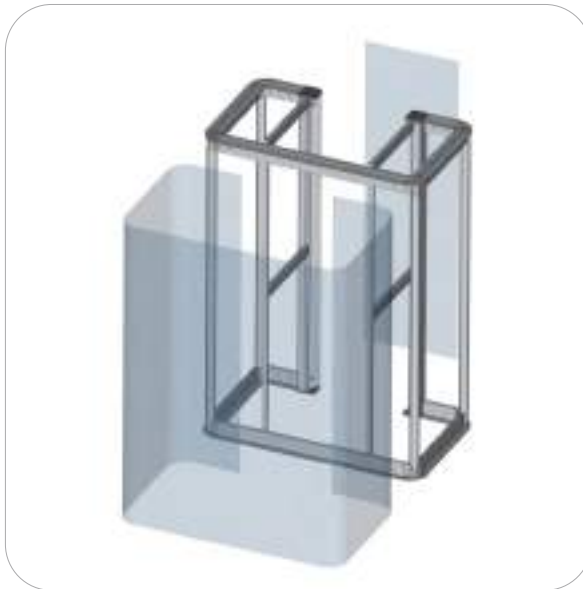

Step 4.

Gather the components to build the counter top and shelf. Use the Exploded View section 3 for part labels.

Reference Connection Method 6 for more details.

Setup is complete.



Connection Methods

Connection Method 1: PMFC2-90-CAP



First, press button to insert the cap into the extrusion. The button will snap in place.

Connection Method 2: PMFC2 / PHFC2



First, with the cam lock disengaged, place the cam lock teeth into the extrusion channel. Second, use the allen key tool to lock it in place. Make half turns clock-wise to engage the cam lock. Do not over tighten the lock buttons.

Connection Method 3: CB10-R / PHFC2



First, press and hold the snap button while you slide it into the tube. The snap button connection is secure when it protrudes through the tube hole. Second, using the allen key tool, disengage the cam lock in the extrusion end and place its teeth into the CB10-R channel. Third, with the cam lock teeth in the channel, use the allen key tool to engage the cam lock. Make a half turn to lock, do not over tighten. Repeat for opposite end.

Connection Method 4: CAM LOCK / PE



First, with the cam lock disengaged, place the cam lock teeth into the extrusion channel. Second, use the allen key tool to lock it in place. Make half turns clock-wise to engage the cam lock. Do not over tighten the lock buttons.

Connection Methods

Connection Method 5: Silicon Edge (SEG)

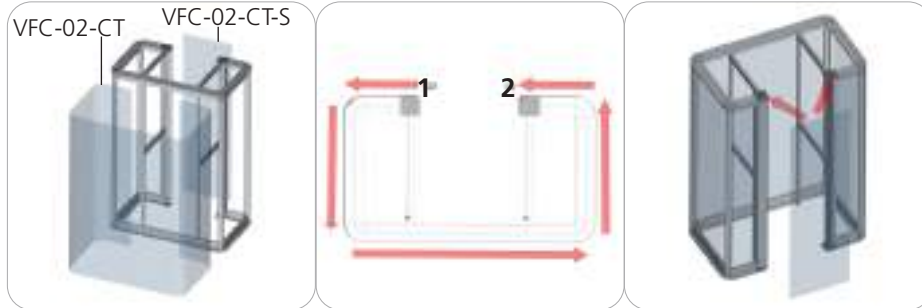

First, at START point 1, start pressing VFC-04-A-G fabric SEG from top to bottom of the counter fabric channels. Second, work the SEG across the rest of the top and bottom counter fabric channels to END point . At END point 2, start pressing the fabric SEG from top to bottom of the counter fabric channel. Third, apply VFC-04-B-G fabric SEG from top to bottom of the counter fabric channels.

Connection Method 6: Counter Top

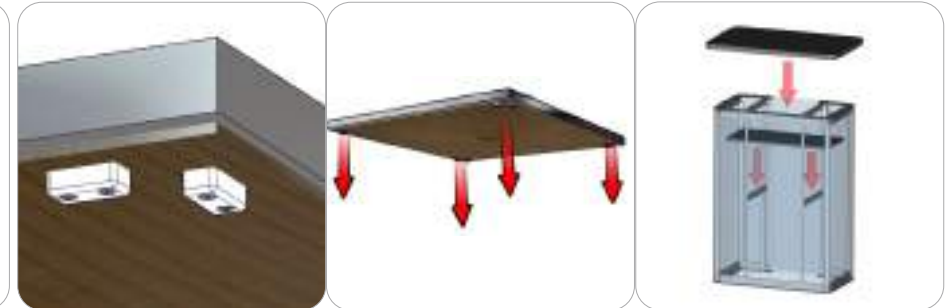

Counter top is held into place by the blocks seen about.