

Hybrid Pro Modular Kit 03

HP-K-03

Hybrid Pro™ Modular exhibits and counters are a perfect solution for the serious exhibitor. Exhibits feature heavy-duty aluminum extrusion frames and push-fit fabric graphics. Count on making an unforgettable impact with Hybrid Pro Modular exhibit kits, counters, and accessories.



features and benefits:

- Silver aluminum extrusion frame
- Illuminated graphic panel with interior top and bottom LED lighting
- Single-sided fabric graphics
- Lifetime hardware warranty against manufacturer defects
- Kit includes frame, side / top white accent, two fabric graphic panels, one illuminated graphic panel, one pillowcase fabric graphic, one backwall counter, one medium monitor mount, two molded cases and one wood crate

dimensions:

Hardware

Graphic

Assembled unit:
111.63" w x 94.75" h x 30.38" d
2835mm(w) x 2407mm(h) x 772mm(d)

Refer to related graphic template for more information.

Approximate weight:
164 lbs / 75 kg

Visit:
<https://www.theexhibitorshandbook.com/download-graphic-templates>

Shipping

additional information:

Packing case(s):
2 OCH2
1 WOODCRATE

Graphic materials:
Dye-sublimation SEG push-fit fabric

Shipping dimensions:
OCH2:
52" l x 29" h x 15" d
1321mm(l) x 737mm(h) x 381mm(d)

Backwall Counter:
Laminate cabinet with locking storage door and custom side / top laminate accent panel
21.9" w x 38.24" h x 17.72" d
557mm(w) x 971mm(h) x 450mm(d)

1 WOODCRATE
48" l x 30" h x 27" d
1219mm(l) x 762mm(h) x 686mm(d)

Max counter weight = 50 lbs / 23 kg

Approximate total shipping weight:
396 lbs / 180 kg

Monitor mount holds 32 - 55" LCD's
Monitor max weight 50 lbs / 37 kg

*LCD monitor not included



This product may include the following materials for recycle:
aluminum, select wood, fabric, cardboard, paper, steel, and plastics.

Panel Colors:



grey



black



white

We are continually improving and modifying our product range and reserve the right to vary the specifications without prior notice. All dimensions and weights quoted are approximate and we accept no responsibility for variance. E&OE. See Graphic Templates for graphic bleed specifications.

Included In Your Kit

Kits & Tools



HP-FS-1 x1



HPC-01-B x1



HEX KEY SET x1



FABRIC STEAMER-ES x1

Graphics

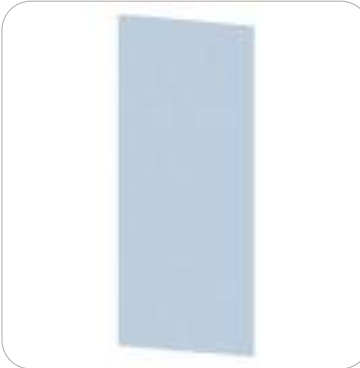

HP-03-A-G x1



HP-03-B-G x1



HP-03-C-G x1



HP-03-D-G x1



HP-03-E-G x1

Included In Your Kit - Sections 1 and 2

Section 1 Components, & Connectors



PHFC4-900-MCB9-MCB9 x2



PHFC4-900-L1-MCB9 x2



PHFC4-1200-L1-MCB9 x1



PHFC4-1200-L1-MCB9-GR x1



PM452-810-L-L x1

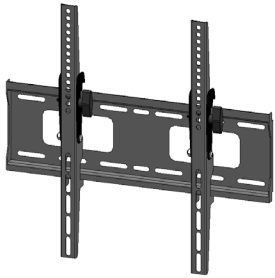

EXT-M-MB x1



CB9 x4



IB2 x2



WME-1200 x1



SW-FOOT-500-LN x2

Section 2



PHFC2-510-L-L x2



PHFC2-855-L-L1-SIDE x4

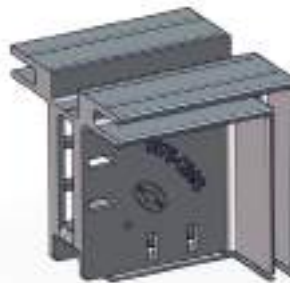

CB9-S x4



IB2 x2

Included In Your Kit - Section 3

Components, & Connectors



PHFC4-1200-MCB9-MCB9 x2



PHFC4-1200-L1-MCB9-RIGHT x2



PHFC4-1200-L1-MCB9-LEFT x1



PHFC4-1200-L1-MCB9-GR-LEFT x1



CBE-50 x4



CB9 x4



IB2 x2



AF16-300-SIDE x2



SW-FOOT-500-LN x2

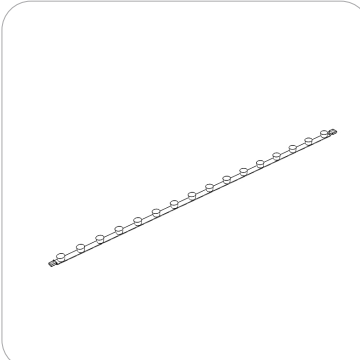

LED-WHT-DB-1100 x4



LED-DB-PWRSUPLY-2 x2



LED-DB-PWRCORD-2 x1

Exploded Diagram - Section 1

HP-K-03

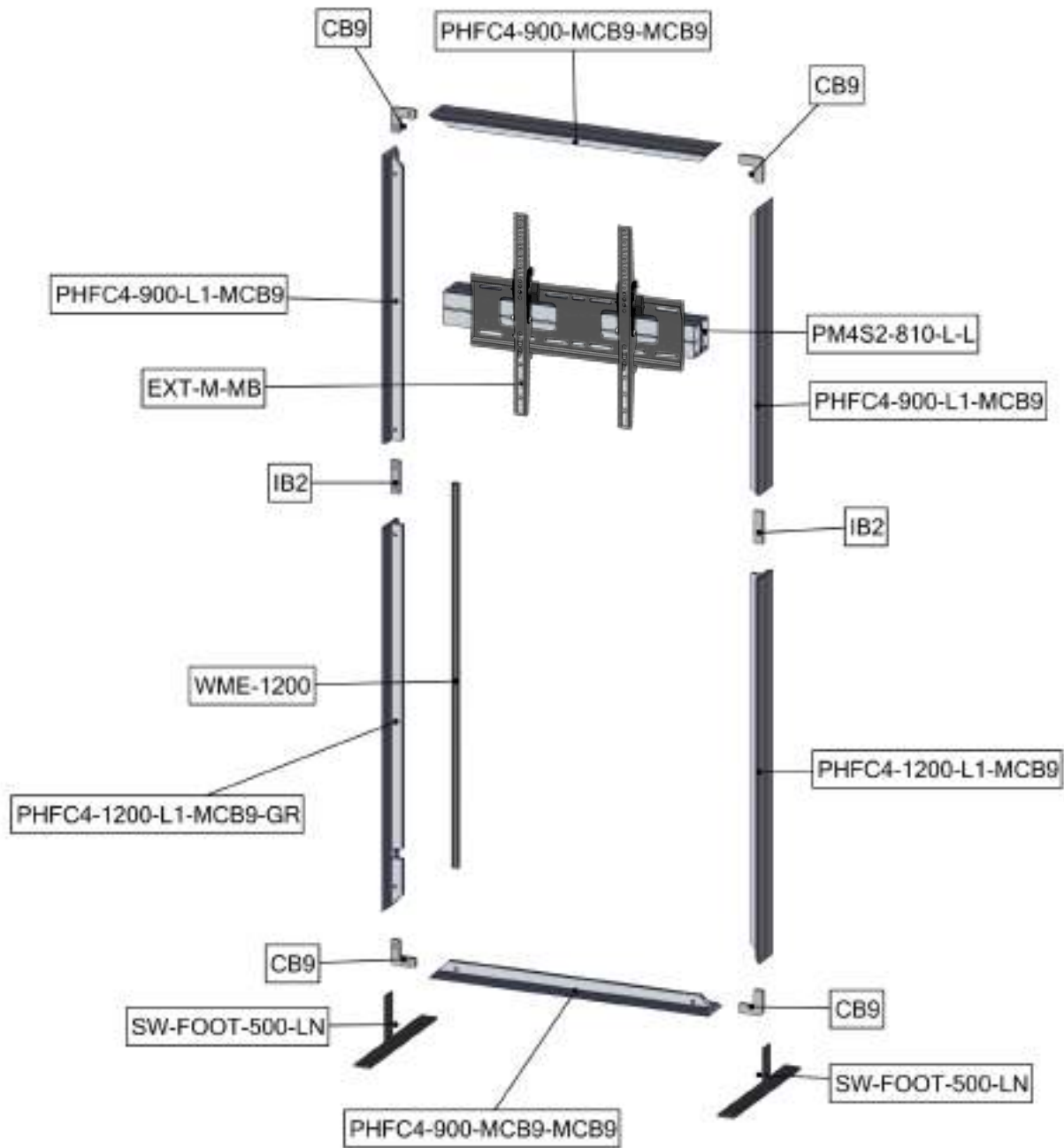

Exploded Diagram - Section 2

HP-K-03

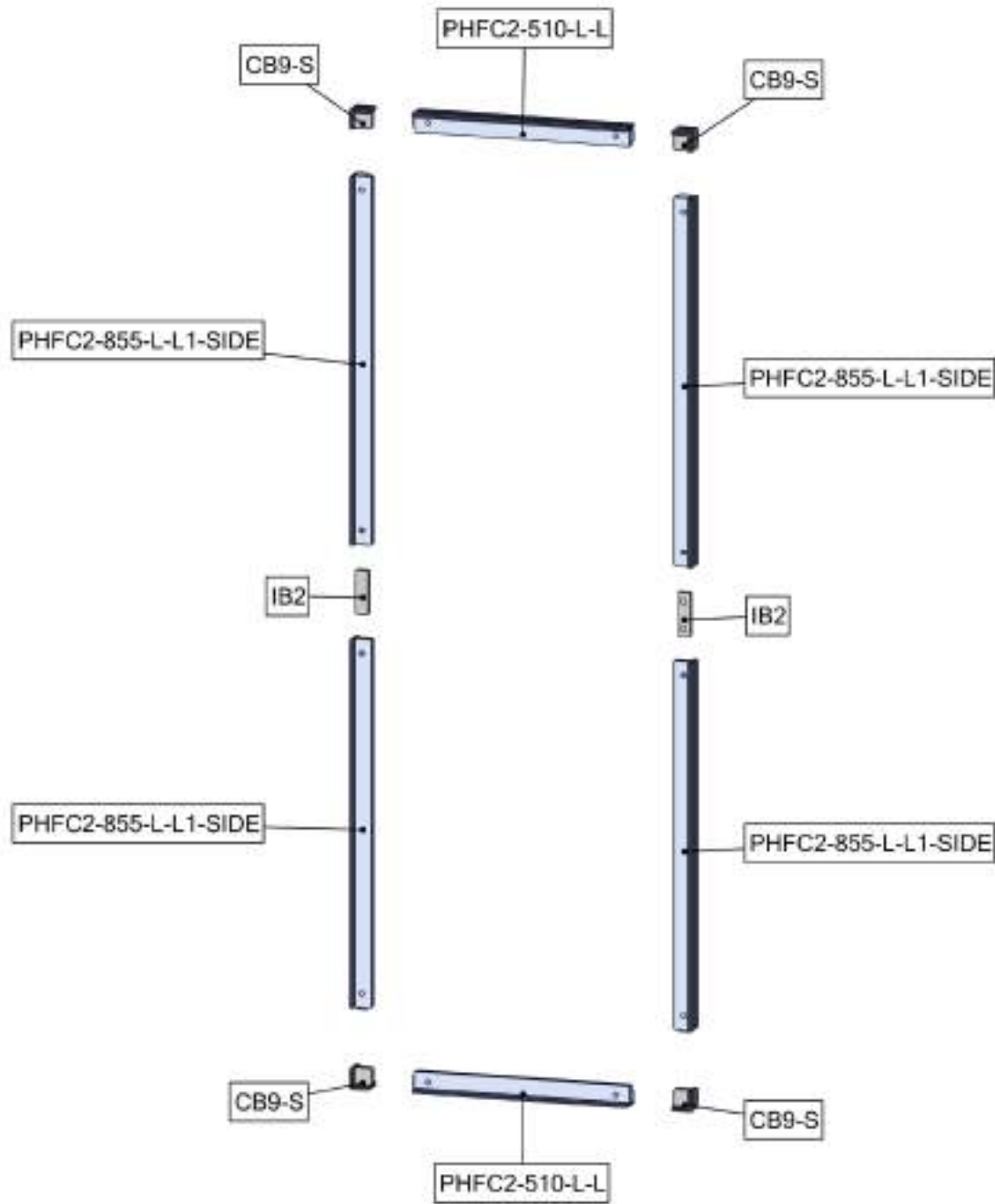

Exploded Diagram - Section 3

HP-K-03

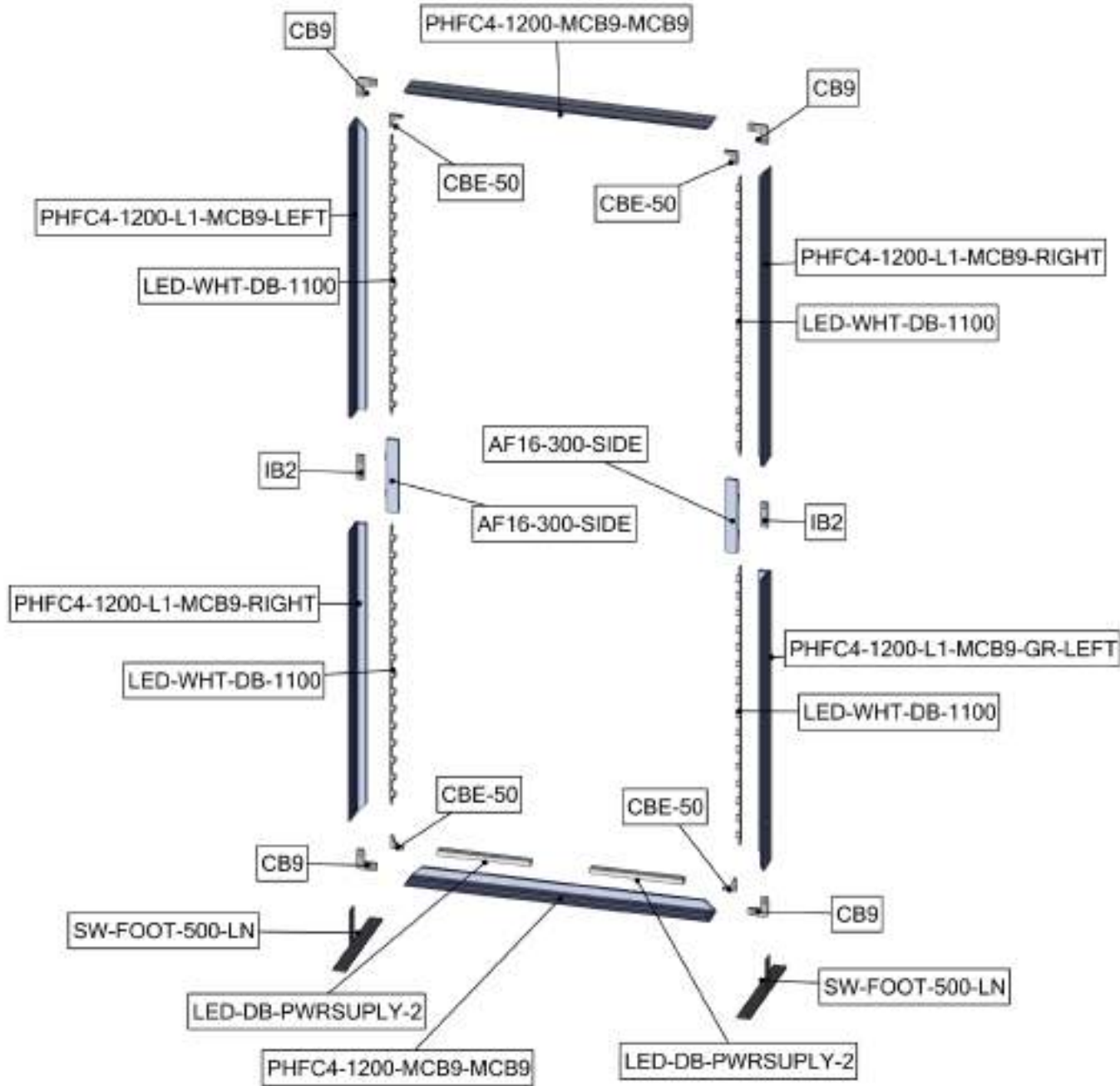

Internal Lighting Diagram - Section 3

HP-K-03

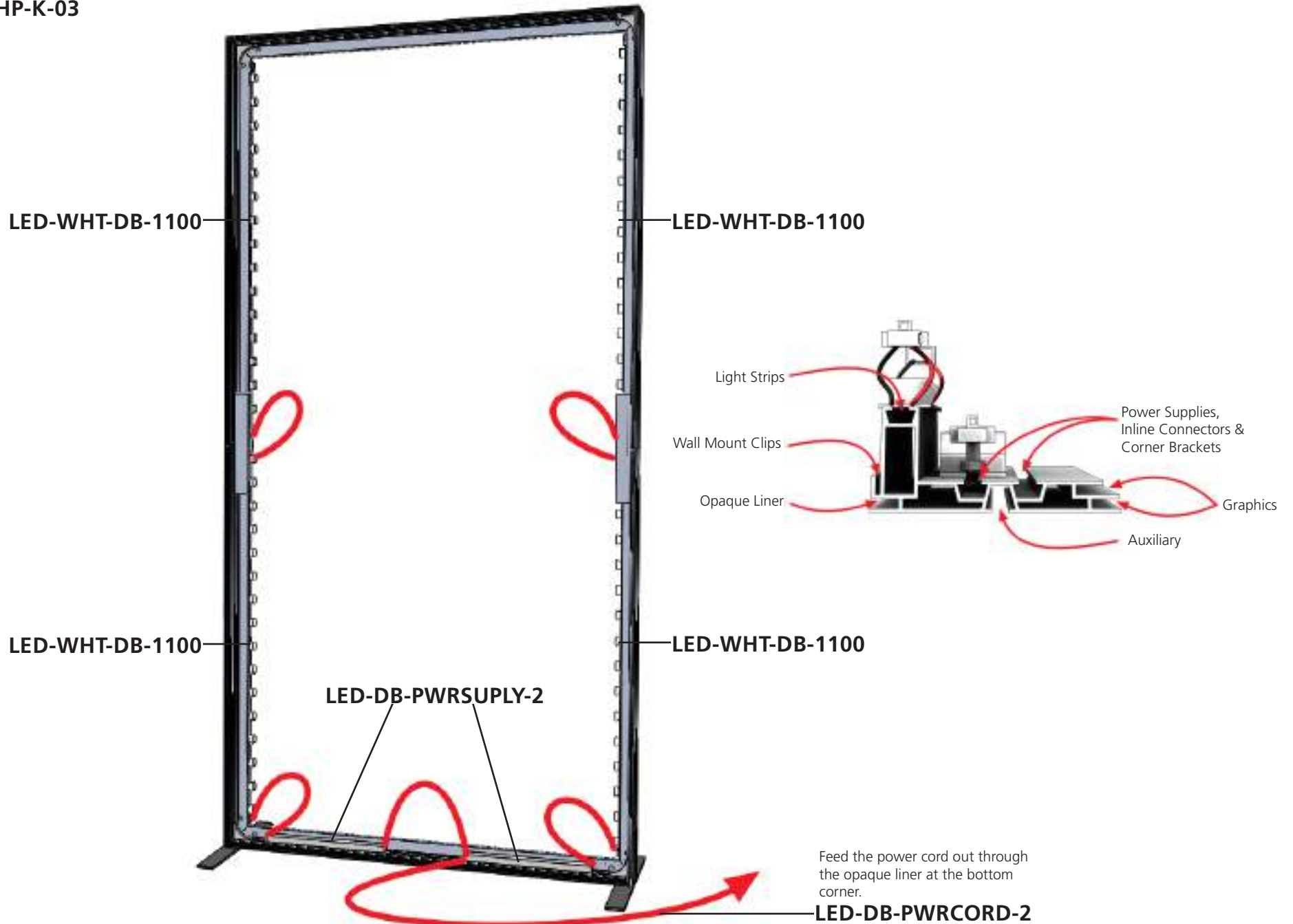

Kit Assembly

Step by Step

Step 1.

Gather the components to build the frame for Section 1. Use the Exploded Diagram for part labels.

Reference Connection Method(s) 1, 2, 3, 4 and 5 for more details. The cable in the WME for the monitor will be connected to your display in a later step.



Take the monitor mount bolts and pre-set them onto the horizontal PM4S2 channel.

Space the bolts apart on center to match the holes of Graphic panel A.



Step 2.

Gather the components to build the frame for Section 2. Use the Exploded Diagram for part labels.

Reference Connection Method(s) 1 and 6 for more details.



Step 3.

Gather the components to build the frame for Section 3. Use the Exploded Diagram for part labels. Use the Internal Lighting Diagram for installing the lights.

Reference Connection Method(s) 1, 2, 4, 7 and 8 for more details.



Step 4.

Gather the frame Sections 1, 2 and 3 to build the backwall. Frame Section 2 will cam lock onto Section 1 and 3. Section 2 will rest on the tops of the stabilizing bases for positive location.

Reference Connection Method(s) 9 for more details.



Kit Assembly

Step by Step

Step 5.

Gather the Graphic Panels A, B, C and Opaque Liner D. Attach them to their respective frame section with the silicon edge perimeter.

Reference Connection Method(s) 10 for more details.

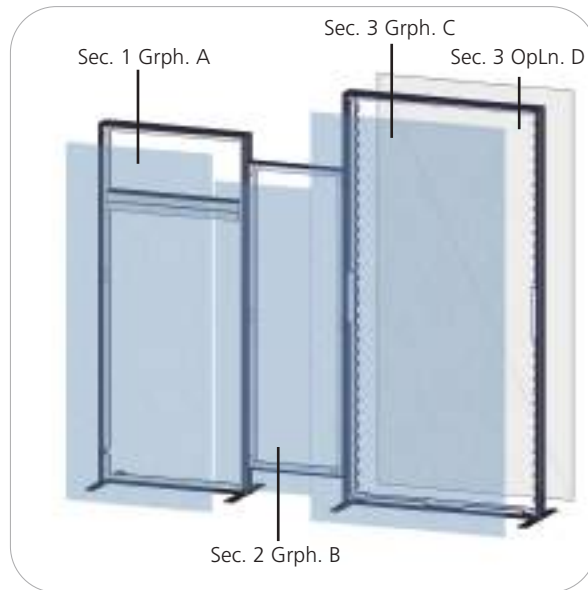

Step 6.

Take the monitor mount and attach it to frame Section 1 with pre-set bolts from Step 1 going through Graphic A.

Reference the Extrusion Monitor Mount Supplemental Sheets for more details.



Step 7.

Build the HP-FS-1 canopy frame and attach the zipper pillowcase.

Reference the Hybrid Pro Fabric structure 1 Instruction Sheets for more details.



Step 8.

Attach the canopy to the backwall and place the HPC-01-B counter in place.

Reference the Hybrid Pro Fabric structure 1 Instruction Sheets for more details.

Setup is complete.



Connection Methods

Connection Method 1: IB2



First, insert the in-line connector into the extrusion while holding in the lock button. Then, slide the next extrusion onto the same in-line connector again holding in the lock button. Finally, use the provided allen key to lock the in-line connector in place. Use the allen key tool to turn the lock buttons, make quarter turns and do not over tighten the lock buttons.

Connection Method 2: CB9



First, insert the corner connector into the extrusion while holding in the lock button. Then, slide the next extrusion onto the same corner connector again holding in the lock button. Finally, use the provided allen key to lock the corner connector in place. Use the allen key tool to press the lock buttons, make quarter turns and do not over tighten the lock buttons.

Connection Method 3: PM4S2



First, with the cam lock disengaged, place the cam lock teeth into the extrusion channel. Second, use the allen key tool to lock it in place. Make half turns clock-wise to engage the cam lock. Do not over tighten the lock buttons.

Connection Method 4: SW-FOOT-300/500/650

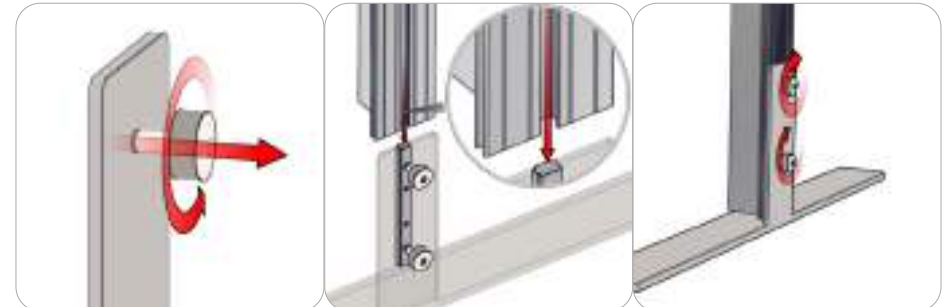

First, loosen the thumb screws and channel bars on the stabilizing bases. Do not disassemble them. Second, slide channel bars into the frame channel flush with the base of the frame. Finally, tighten the thumb screws and channel bars securing the attachment.

Connection Methods

Connection Method 5: WME



Use the wire management extrusion (WME) to organize the power cords inside of the frame. Press fit the cable into the WME. Take the WME and snap fit onto the extrusion channel.

Connection Method 6: CB9-S



First, with the cam lock disengaged, place the extrusion cam lock teeth into the corner bracket. Second, use the hex key tool to lock it in place. Make half turns clock-wise to engage the cam lock. Do not over tighten the lock buttons.

Connection Method 7: AF16-300-SIDE



For single sided graphics, attach the AF16 connector into channel (B, featured above).
For double sided graphics, attach the AF16 connector into channel (A).

The cam lock buttons should face towards the back of the frame. Be sure to evenly bridge the AF16 on the extrusion split for maximum support. Using the allen key tool, engage the cam-lock teeth by turning the buttons a half turn clock-wise. Do not over tighten the cam-lock buttons.

Connection Method 8: CBE-50

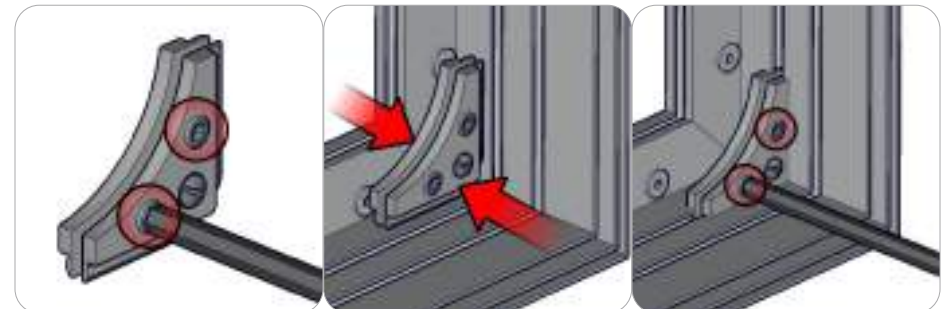

First, use the provides hex tool to loosen the two 5mm hex set screws. Next, compress the bracket and apply it to the corner channel. Then, tighten the set screws. Do not over tighten the set screws. Do not loosen the spring loaded screw.

Connection Methods

Connection Method 9: SIDE CAM LOCKS



First, using the provided hand tool, disengage the cam lock by rotating counter clock-wise 1/2 turn. Second, place the cam lock teeth into the next extrusion channel and make a 1/2 turn clock-wise to engage the cam lock. Do not over tighten the cam lock.

Connection Method 10: Graphic Application

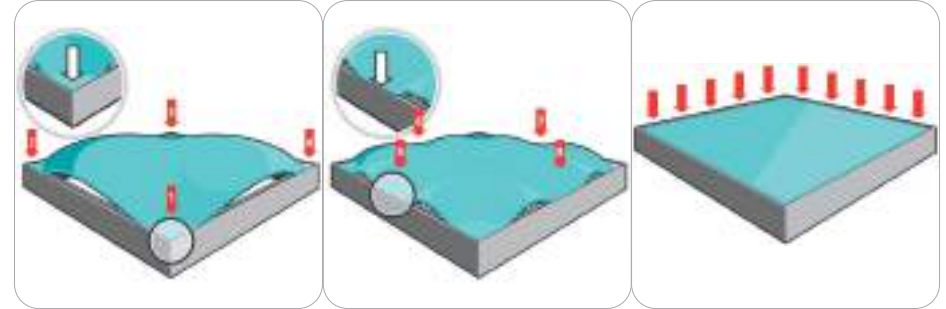

First, insert the silicone edge frame corners into the frame graphic channel (points 1 through 4). Second, insert the silicone edge frame sides into the frame graphic channel (points 5 through 8). Third, push the remaining silicone edge fabric into the frame graphic channel. Similar setup is recommended for the opaque liner. To remove these panels, simply pull the loop tag sewn near a corner.

Monitor Bracket Instructions

Extrusion Channel Applications



EXT-SM-MB

Vesa Pattern: 75 x 75
up to 200 x 200mm

Max weight varies per application

Assembled unit:

10" w x 8.86" h x 2" d
255mm (w) x 225mm (h) x 50mm (d)

Shipping dimensions:

14" l x 6" h x 4" d
356mm (l) x 152mm (h) x 102mm (d)

Approximate total shipping weight:

6 lbs / 3 kg

Recommended monitor sizes:

23" - 42"

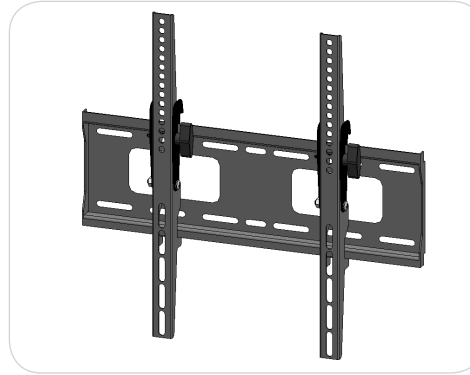

EXT-M-MB

Vesa Pattern: 200 x 200
up to 400 x 400mm

Max weight varies per application

Assembled unit:

17.6" w x 16.7" h x 1.6" d
448mm (w) x 425mm (h) x 40mm (d)

Shipping dimensions:

24" l x 4" h x 4" d
610mm (l) x 102mm (h) x 102mm (d)

Approximate total shipping weight:

8 lbs / 4 kg

Recommended monitor sizes:

32" - 55"

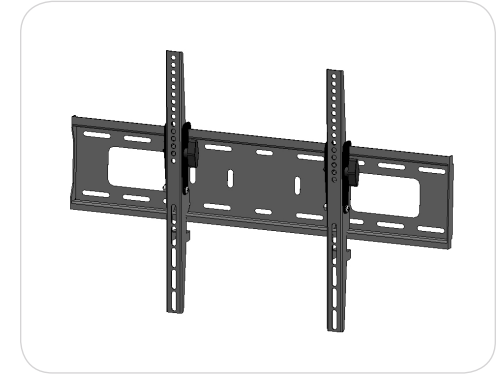

EXT-LG-MB

Vesa Pattern: 200 x 200
up to 600 x 400mm

Max weight varies per application

Assembled unit:

25.9" w x 16.7" h x 1.6" d
658mm (w) x 425mm (h) x 40mm (d)

Shipping dimensions:

28" l x 6" h x 6" d
711mm (l) x 152mm (h) x 152mm (d)

Approximate total shipping weight:

9 lbs / 5 kg

Recommended monitor sizes:

37" - 70"

Included hardware:



LN-100

x2



M5 x 10

LN-LCD-SCW

x2



1/4"-20 x 1"

BOLT-1

x2

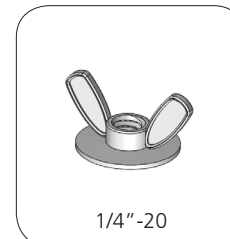

1/4"-20

Flange Wing nut

x2

Extrusion Connection

Channel Connection A

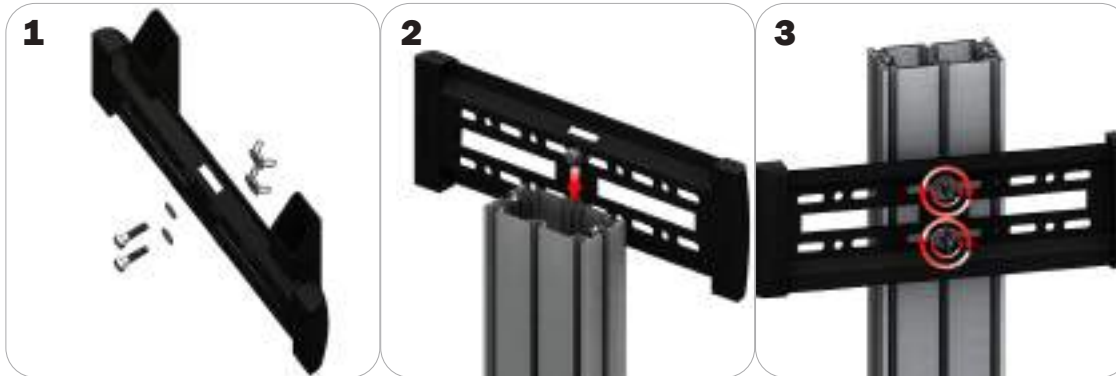

Locate all components needed to assemble the monitor mount with the channel connection A method. You will need (1) monitor bracket, (2) square head bolts, (2) washers, and (2) wing nuts.

Step 1: Insert the provided bolts through the washers and center top and bottom holes of the monitor mount. Loosely thread your wing nuts onto the end of the bolts.

Step 2: Slide the bolt heads down the extrusion channel.

Step 3: Tighten your wing nuts to lock the monitor bracket in place.

Step 4: Reference the included manufacturer monitor mount instructions for fastening your monitor to the bracket.

Channel Connection B

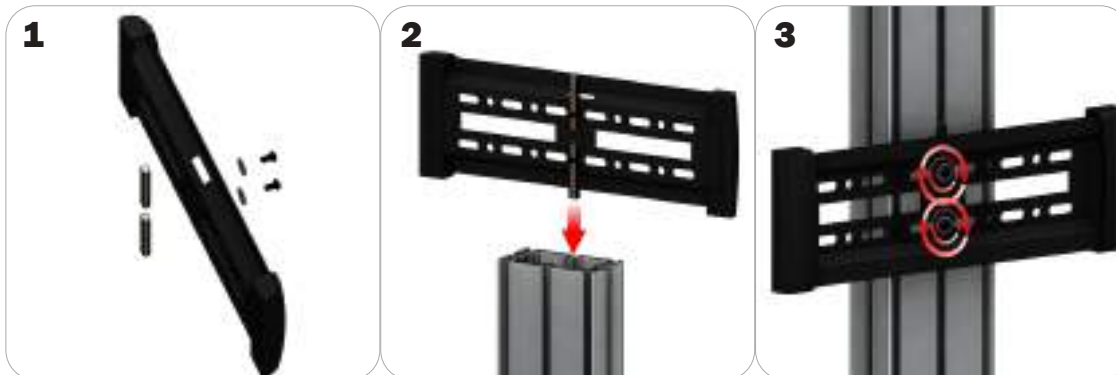

Locate all components needed to assemble the monitor mount with the channel connection B method. You will need (1) monitor bracket, (2) LN-LCD-SCW, (2) LN-100, and (2) washers.

Step 1: Loosely thread the LN-LCD-SCW screws through the washers, the center top and bottom holes of the monitor bracket, and through the LN-50 holes.

Step 2: Slide the LN-100s down the extrusion channel.

Step 3: Tighten your LN-LCD-SCW to lock the monitor bracket in place.

Step 4: Reference the included manufacturer monitor mount instructions for fastening your monitor to the bracket.

Extrusion Connection

TRI-30MM Channel Tube Connection



Locate all components needed to assemble the monitor mount with the TRI-30MM Channel Tube Connection method. You will need (1) monitor bracket, (2) Square Bolts, and (2) Wingnuts.

Step 1: Slip the head of the square bolts into the extrusion channel of the tube.

Step 2: Apply your monitor bracket to the protruding square bolts.

Step 3: Lock your monitor bracket to the square bolts using the provided wingnuts.

Step 4: Reference the included manufacturer monitor mount instructions for fastening your monitor to the bracket.

Hybrid Pro Counter 01-B

HPC-01-B

All Hybrid Pro™ Modular counters feature accessible storage and locking doors. Purchased magnet applied graphic panel allows for your messaging and branding.



features and benefits:

- 30mm aluminum stand offs
- Laminated cabinet with locking doors
- Laminated adjustable counter top
- 2 T-handle allen key tools included
- Kit includes an adjustable counter top and one wood crate
- Lifetime hardware warranty against manufacturer defects

dimensions:

Hardware

Graphic

Assembled unit:
21.9" w x 38.24" h x 17.72" d
557mm(w) x 971mm(h) x 450mm(d)

Approximate weight:
44 lbs / 20 kgs

Refer to related graphic template for more information.

Visit:
www.exhibitors-handbook.com/graphic-templates

Shipping

additional information:

Packing case(s):
1 HPC-01-B-CRATE

Shipping dimensions:
48" l x 31" h x 27" d
1220mm(l) x 787mm(h) x 686mm(d)

Approximate total shipping weight:
182 lbs / 83 kgs

Recommended tools:
1/2" hex head wrench keys, not included

Panel Colors:



grey

black

white



This product may include the following materials for recycle:
aluminum, select wood, fabric, cardboard, paper, steel, and plastics.

We are continually improving and modifying our product range and reserve the right to vary the specifications without prior notice. All dimensions and weights quoted are approximate and we accept no responsibility for variance. E&OE. See Graphic Templates for graphic bleed specifications.

Included In Your Kit

Tools, Components, & Connectors



5MM ALLEN-T x1



T-HANDLE-5-32 x1



5/16" - 18 X 2"
SET SCREWS x9



5/16" - 18 X 2"
HEX BOLTS x4



CAM LOCK 2010 x4



5/16" - 1 1/4" OD
FENDER WASHERS x4



TUBE-30-ASY-1 x5



TUBE-30-ASY-2 x4



HPC-01-B-CAB x1



HPC-01-B-CT x1



HPC-01-B-INT x1

Included In Your Kit

Graphic

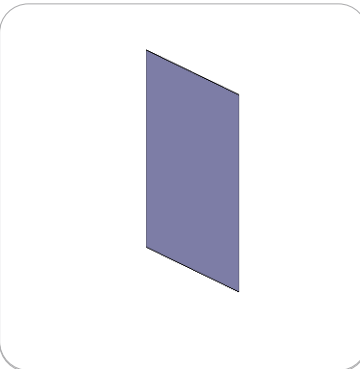

HPC-01-B-G x1

Connection Methods

Connection Method 1: CAM LOCK



First, with the cam lock disengaged, place the cam lock teeth into the extrusion channel. Second, use the allen key tool to lock it in place. Make half turns clock-wise to engage the cam lock. Do not over tighten the lock buttons.

Connection Method 2: TUBE-30-ASY-1 / TUBE-30-ASY-2

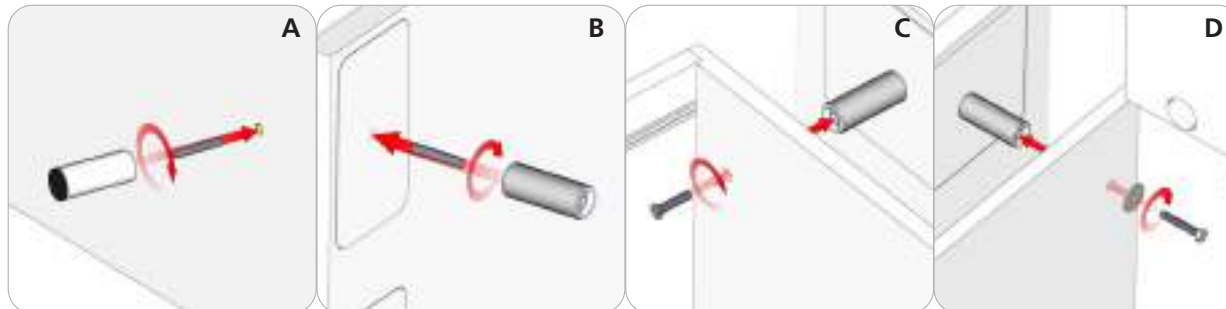

Image A. Use the hex key tool to drive the 2" set screw into the panel. Then, hand tighten the 30mm tube assembly 1 onto the set screw.

Image B. Use the hex key tool, to drive the 2" set screw into the panel. Then, hand tighten the 30mm tube assembly 2 onto the set screw.

Image C. Drive the countersink screws into the 30mm tube assembly 2.

Image D. Use a 1/2" hex wrench (tool not included) to drive the hex bolt and washer into the 30mm tube assembly 2.

Kit Assembly

Step by Step

Step 1.

Use the provided hex key tool for attaching the 4 set screws. Make sure the set screws are flush to the inside surface and do not protrude into the cabinet. Next, hand tighten the 30mm tube feet onto the set screws.

Reference Connection Method 3 Image A for more details.

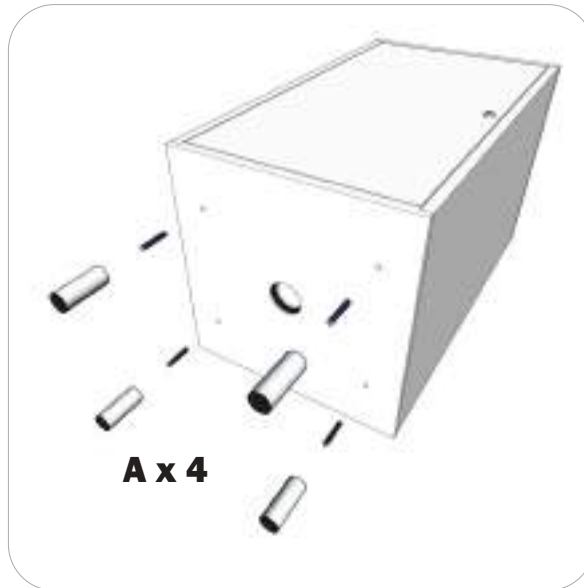

Step 2.

Use the provided hex key tool for attaching the 5 set screws to the counter top. Next, hand tighten the 30mm tube posts onto the set screws.

Reference Connection Method 3 Image A and B for more details.



Step 3.

Use a 1/2" hex wrench (tools not included) for attaching the four 30mm tube posts of the countertop onto the cabinet.

Reference Connection Method 3 Image D for more details.

This counter top can be assembled on the left or right.



Step 4.

Using the provided allen key tool, attach the 4 camlocks into the cabinets inside extrusion channels. Make sure they are all at the same height and level for the internal shelf.

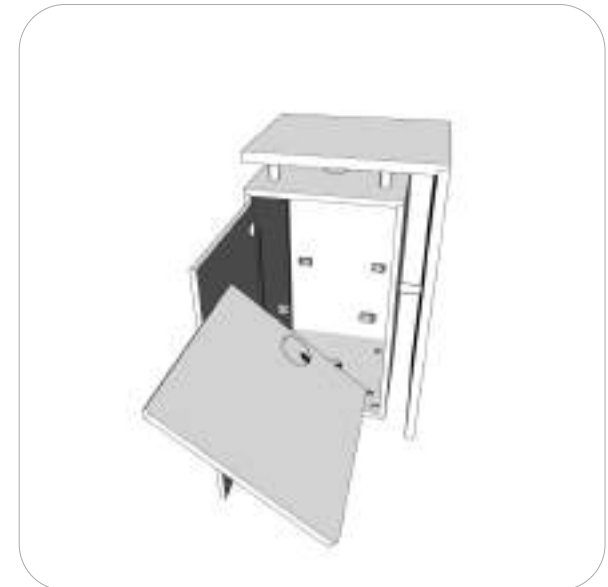

Kit Assembly

Step by Step

Step 5.

Attach UV printed graphic,
adhesive backed vinyl to door.

