

# Hybrid Pro Modular Kit 08

## HP-K-08

Hybrid Pro™ Modular exhibits and counters are a perfect solution for the serious exhibitor. Exhibits feature heavy-duty aluminum extrusion frames and push-fit fabric graphics. Count on making an unforgettable impact with Hybrid Pro Modular exhibit kits, counters, and accessories.



## features and benefits:

- Silver aluminum extrusion frame
- Slot wall
- Single-sided fabric graphics
- UV graphic
- Counter available in four thermoformed finishes, shown below
- Kit includes frame, slot wall, one fabric graphic panel, eight white Sintra infills, one counter, one medium monitor mount, one spotlight, and three molded cases
- Lifetime hardware warranty against manufacturer defects

## dimensions:

### Hardware

Assembled unit:  
114.13" w x 94.5" h x 19.63" d  
2899mm(w) x 2400mm(h) x 499mm(d)

Approximate weight:  
205 lbs / 93 kg

### Graphic

Refer to related graphic template for more information.

Visit:  
[www.exhibitors-handbook.com/graphic-templates](http://www.exhibitors-handbook.com/graphic-templates)

### Shipping

Packing case(s):  
1 OCFM  
2 OCH2

Shipping dimensions:  
OCFM:  
49" l x 39" h x 15" d  
1245mm(l) x 991mm(h) x 381mm(d)

OCH2:  
52" l x 29" h x 15" d  
1321mm(l) x 737mm(h) x 381mm(d)

Approximate total shipping weight:  
300 lbs / 136 kg

## additional information:

Graphic material:  
Dye-sublimation SEG push-fit fabric  
UV printed on 6mm white Sintra

Backwall Counter:  
25.5" w x 39.2" h x 15.1" d  
648mm(w) x 996mm(h) x 384mm(d)

Counter holds max weight 50 lbs / 23 kg

Monitor bracket holds 32"-55" LCDs  
Maximum weight: 50 lbs / 37 kg

\*monitor not included

### Tabletop Colors:



2 person assembly recommended:



This product may include the following materials for recycle:  
aluminum, select wood, fabric, cardboard, paper, steel, and plastics.

We are continually improving and modifying our product range and reserve the right to vary the specifications without prior notice. All dimensions and weights quoted are approximate and we accept no responsibility for variance. E&OE. See Graphic Templates for graphic bleed specifications.

# Included In Your Kit

Tools, Components, & Connectors



HEX KEY SET x1

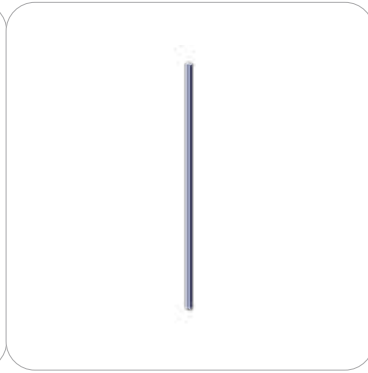

L180N-600 x2

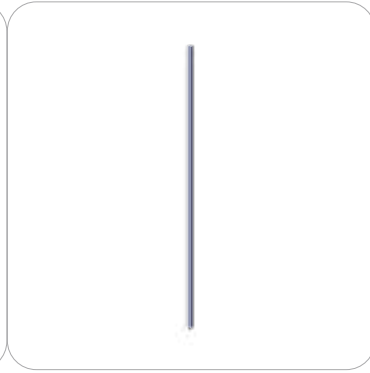

L180N-900 x4

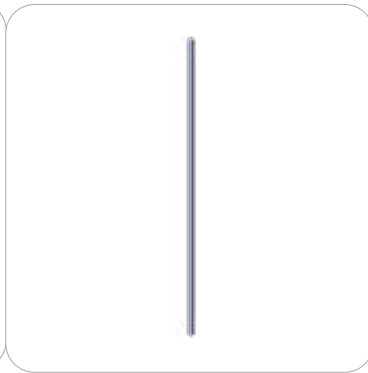

P180-1200 x4



PH1-100-L-L x1



PH-300-L-L x12



PHFC4-1200-L1-MCB9 x2



PHFC4-1200-L1-MCB9-SIDE x2



PHFC4-1200-MCB9-MCB9 x2



PM4D-300-TG x1



PM4D-600-TG x4

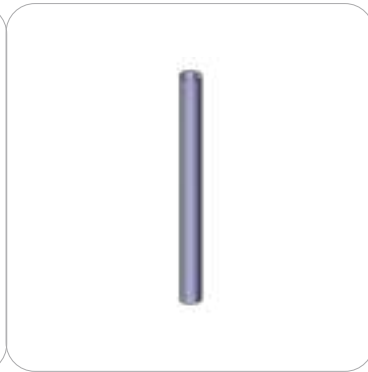

PM4R8-1155-A165-L x2

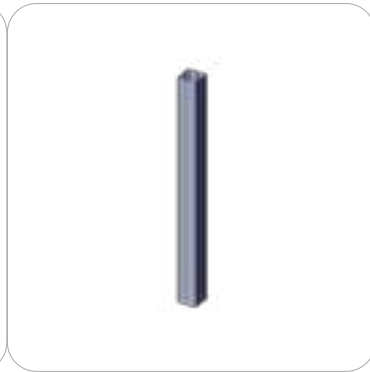

PM4S2-1200-A315-A315 x6



PS-900-1200 x2



CB9 x4

# Included In Your Kit

Components



IB2 x2

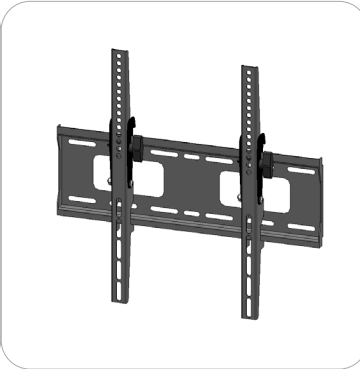

EXT-M-MB x1



LN-CU-06 x1

Graphics

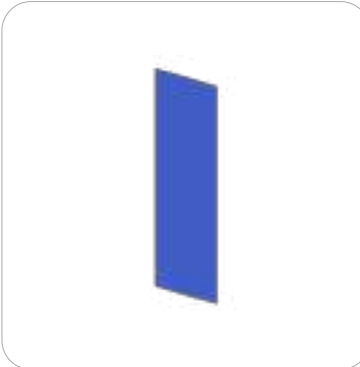

HP-08-A-G x1



HP-08-B-G x1

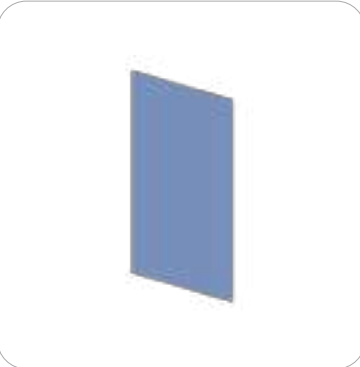

HP-08-C-G x1

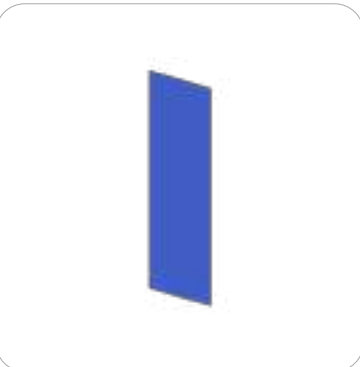

HP-08-D-G x1



HP-08-E-G x1

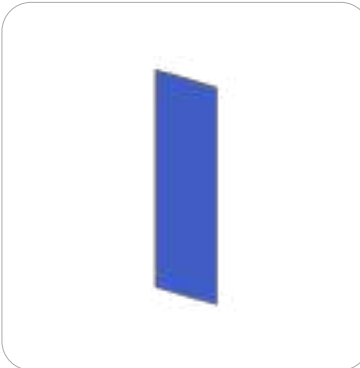

HP-08-F-G x1



HP-08-G-G x1



HP-08-H-G x1



HP-08-I-G x1

# Exploded View

HP-K-08

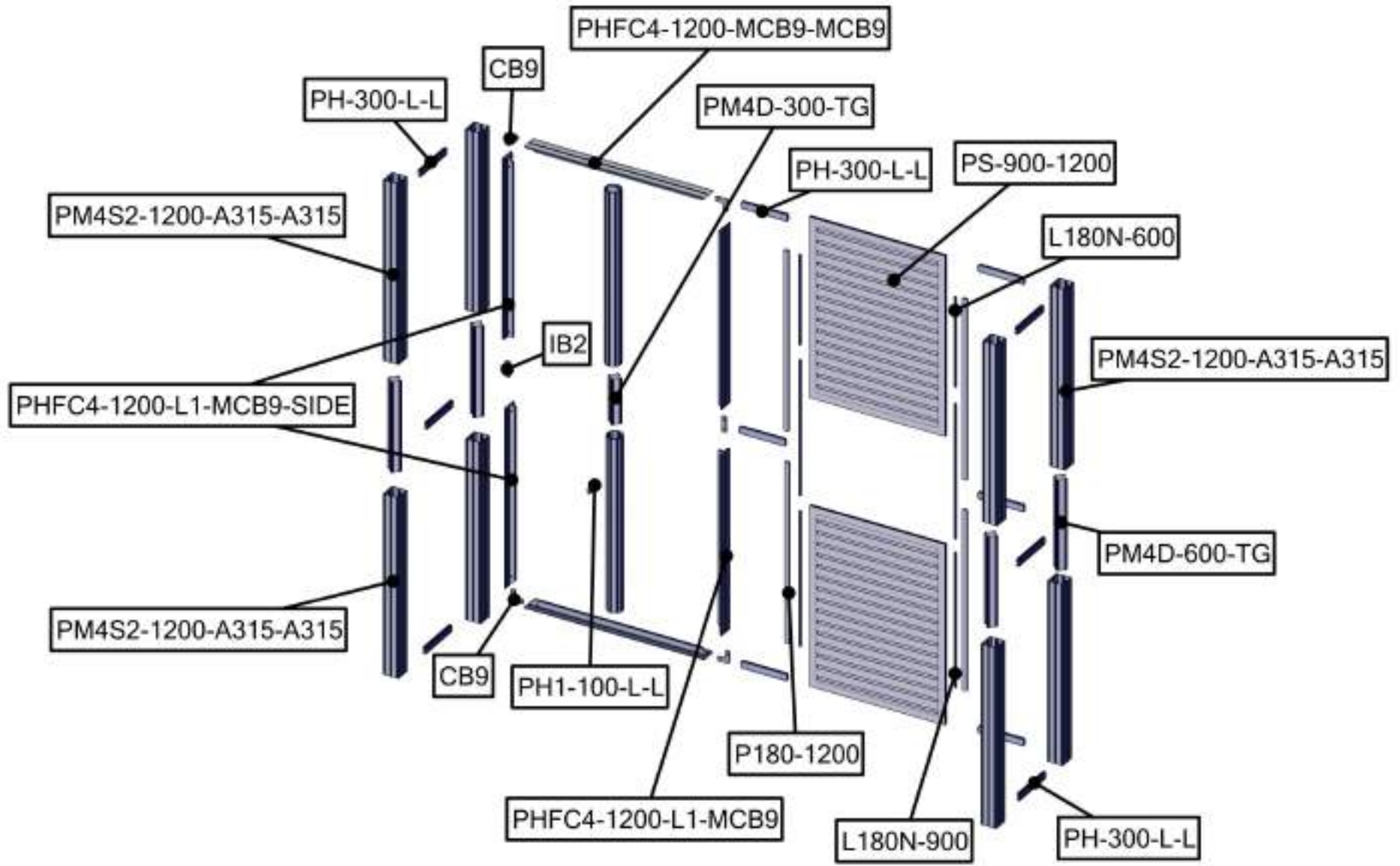

# Kit Assembly

## Step by Step

### Step 1.

Gather the components to build the first part of the frame. Use the Exploded View for part labels.

Reference Connection Method 1 and 2 for more details.



### Step 2.

Gather the components to build the second part of the frame and connect it to the first part. Use the Exploded View for part labels.

Reference Connection Method 3 for more details.



### Step 3.

Gather the components to build the third part of the frame. Use the Exploded View for part labels.

Reference Connection Method 3 for more details.



### Step 4.

Gather the components to build the final part of the frame and attach it to the rest of the frame. Use the Exploded View for part labels.

Reference Connection Method 3 for more details.



# Kit Assembly

## Step by Step

### Step 5.

Attach the spotlight and final graphic to the frame. Connect the PH1-100-L-L to the frame after applying the graphic.

Reference Connection Method 4 for more details.



### Step 6.

Build the counter and connect it to the frame via the PH1-100-L-L. Attach the monitor mount to the main frame.

Setup is complete.



# Connection Methods

## Connection Method 1: CB9



First, insert the corner connector into the extrusion while holding in the lock button with the allen key tool. Second, slide the next extrusion onto the same corner connector while holding in the lock button using the allen key tool. Third, use the allen key tool for locking the corner connector buttons in place. Use the allen key tool to make half turns clock-wise. Do not over tighten the lock buttons.

## Connection Method 2: IB2



First, insert the in-line connector into the extrusion while holding in the lock button with the allen key tool. Second, slide the next extrusion onto the same in-line connector while holding in the lock button using the allen key tool. Third, use the allen key tool for locking the in-line connector buttons in place. Use the allen key tool to make half turns clock-wise. Do not over tighten the lock buttons.

## Connection Method 3: PH-L / PH-S / PHFC2 / PHFC4



First, with the cam lock disengaged, place the cam lock teeth into the extrusion channel. Second, use the allen key tool to lock it in place. Make half turns clock-wise to engage the cam lock. Do not over tighten the lock buttons.

## Connection Method 4: Graphic Application

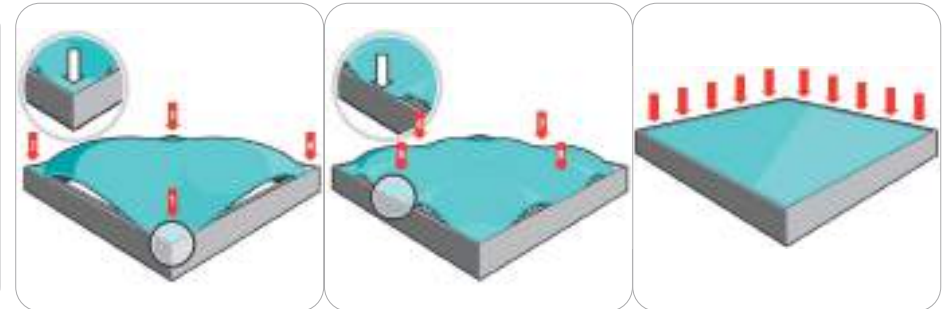

First, insert the silicone edge frame corners into the frame graphic channel (points 1 through 4). Second, insert the silicone edge frame sides into the frame graphic channel (points 5 through 8). Third, push the remaining silicone edge fabric into the frame graphic channel. Similar setup is recommended for the opaque liner. To remove these panels, simply pull the loop tag sewn near a corner.

# Rectangle Counter

## LN-CU-06

Dress up your space with sophisticated and functional counters. Counter tops are available in four thermoform finishes – silver, black, mahogany, and natural. Printed graphic panels create the base of the counter. Comes standard with a locking cabinet door. Custom counter top colors are available.



## features and benefits:

- Custom appearance
- Easy to assemble
- Table top available in four finishes
- Locking door
- Internal shelf
- Installation tool included
- Aluminum frame construction
- Custom top and graphic colors available
- Lifetime limited hardware warranty against manufacturer defects

## dimensions:

### Hardware

Assembled Unit:  
25.43" w x 40.2" h x 15.1" d  
1166mm(w) x 1020mm(h) x 538mm(d)

Approximate weight:  
39 lbs / 18 kg

### Shipping

Packing case(s):  
1 OCH2

Shipping dimensions:  
OCH2:  
52" l x 29" h x 15" d  
1321mm(l) x 737mm(h) x 381mm(d)

Approximate total shipping weight  
(includes case & graphics):  
70 lbs / 32 kg

### Graphic

Refer to related graphic template for more information.

Visit [exhibitors-handbook.com/graphic-templates](http://exhibitors-handbook.com/graphic-templates)

## additional information:

Graphic material:  
UV - 6mm Sintra

Interior Cabinet Dimensions:  
22" w x 39" h x 12" d  
559mm(w) x 991mm(h) x 305mm(d)

Tabletop Dimensions:  
25.43" w x 1.2" h x 15.1" d  
1166mm(w) x 31mm(h) x 538mm(d)

Counter holds max 50 lbs / 23 kg

Shelf holds max 10 lbs / 6 kg

When included in a larger kit, a different packaging solution will be listed to accommodate all contents of the kit. Individual packaging no longer provided.

### Tabletop Colors:



silver

black

mahogany

natural

We are continually improving and modifying our product range and reserve the right to vary the specifications without prior notice. All dimensions and weights quoted are approximate and we accept no responsibility for variance. E&OE. See Graphic Templates for graphic bleed specifications.



# Included In Your Kit

Tools, Components, Connectors, & Extrusions



5MM ALLEN-T x1

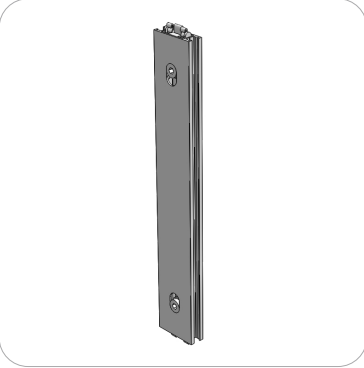

PH-280-S-S x4



V-CAB-01-DR x1



V-CAB-01-FR x1



SS1-S x4

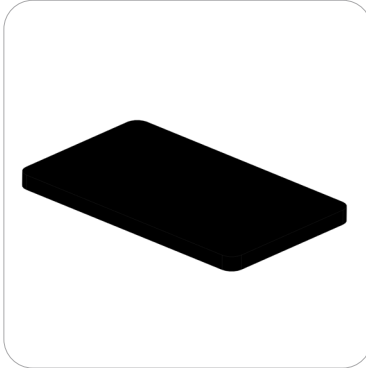

V-CW-CT-01-B x1



V-CU-CAB-01-S x1

Graphics

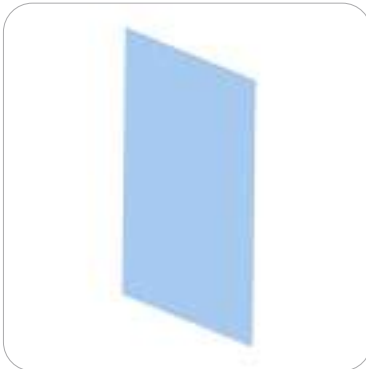

V-CAB-01-GF-FR-01 x1



V-CAB-01-GF-SD x2



V-CAB-01-GF-DR x1

# Exploded View

LN-CU-06

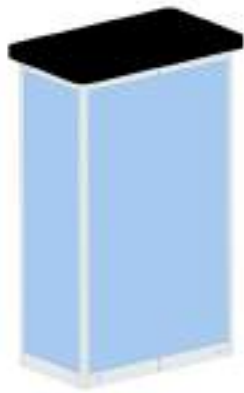

OVERVIEW

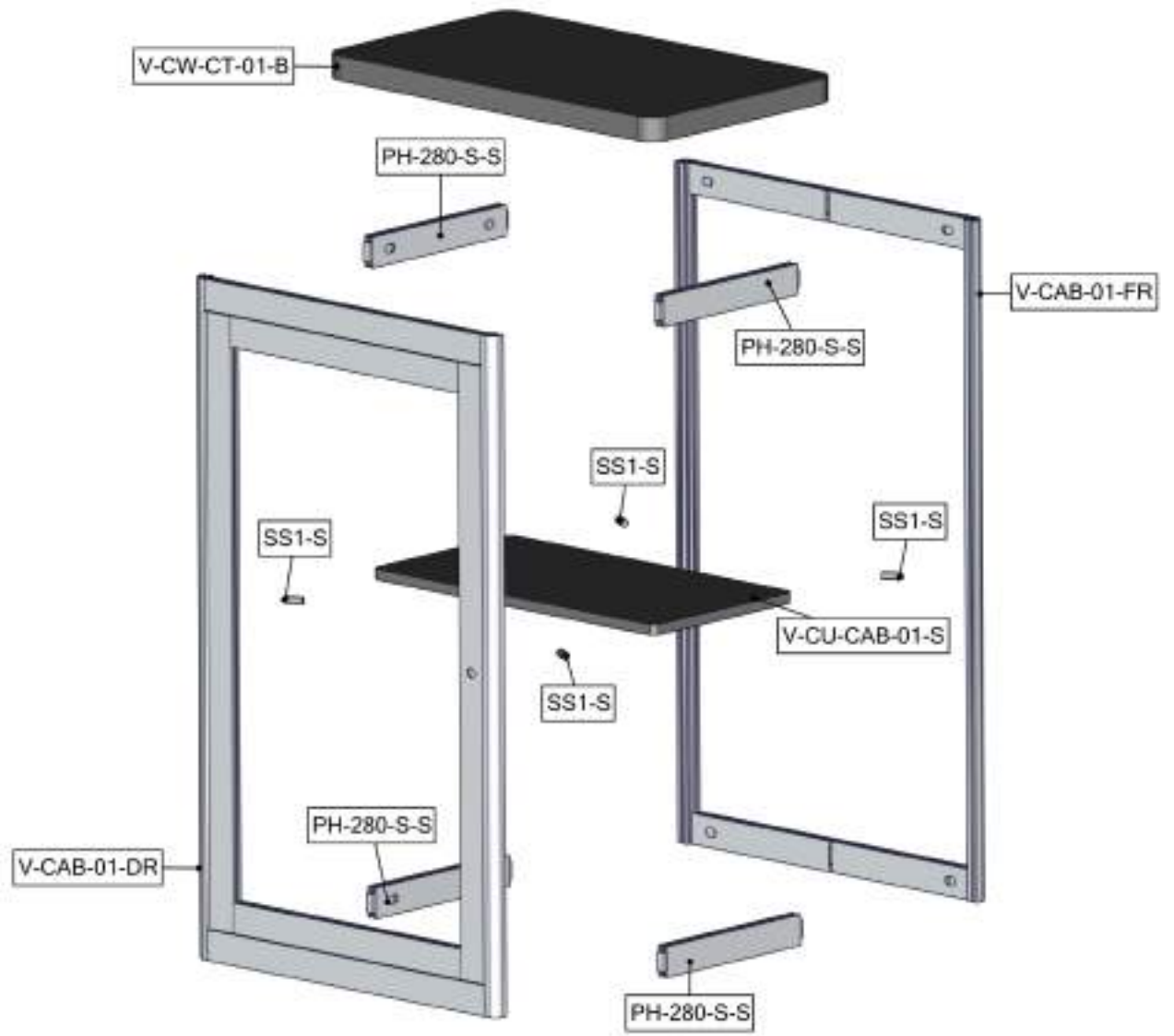
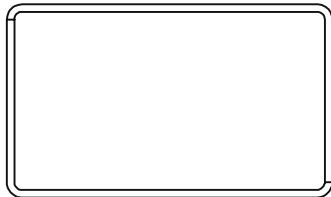

# Kit Assembly

## Step by Step

### Step 1.

Locate your V-CAB-01-DR and V-CAB-01-FR assemblies. Both frames should have pre-installed graphics. V-CAB-01-DR should also have a locking door, test to ensure it is properly functioning.

Reference Connection Method 1 for more details.



### Step 2.

Locate (2) PH-280-S-S extrusions. Lock into place so that the hex bolt heads face inward to the cabinet and the extrusion is flush with the V-CAB-01-DR and V-CAB-01-FR.

Reference Connection Method 1 for more details.

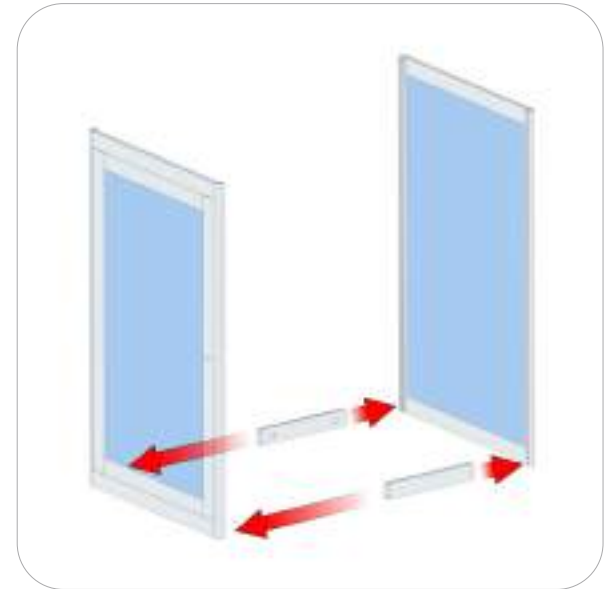

### Step 3.

Locate (2) PH-280-S-S extrusions and cabinet side graphic panels. Slide your graphic into the channels of V-CAB-01-FR and V-CAB-01-DR. Next, lock your PH-280-S-S extrusions above the graphics.

Reference Connection Method 1 for more details.

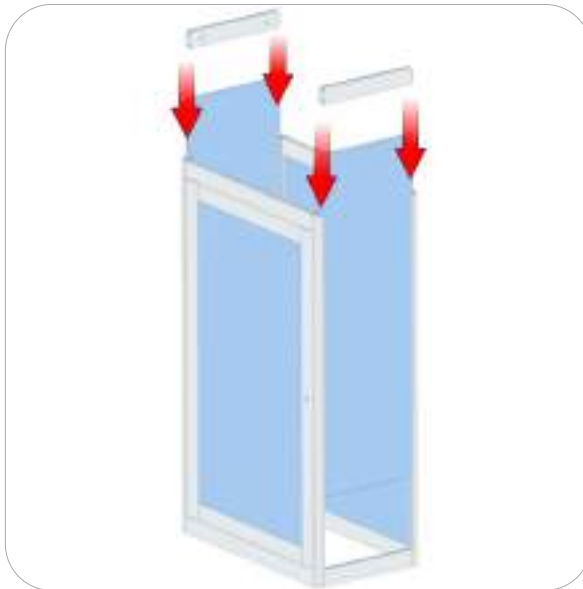

### Step 4.

Locate your V-CW-CT-01-B counter top and V-CU-CAB-01-S shelf. Note the imprinted placement templates on the underside of your counter top. Attach them to the frame.

Reference Connection Method 2 for more details.

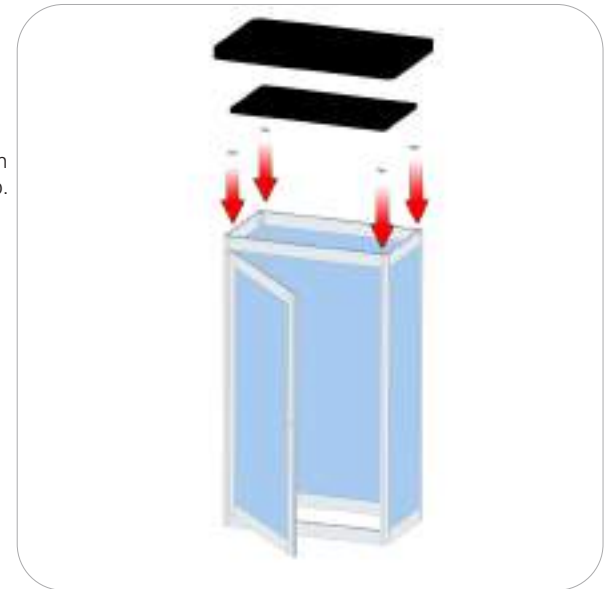

# Connection Methods

Connection Method 1: P90R / PH-L



First, with the cam lock disengaged, place the cam lock teeth into the extrusion channel. Second, use the allen key tool to lock it in place. Make half turns clock-wise to engage the cam lock. Do not over tighten the lock buttons.

Connection Method 2: SS1-1



First, take the shelf support and loosen the set screw to about a 1/4 inch gap. Do not remove it. Second, slide the shelf support into the 3mm center channel. Turn the shelf support clock wise to lock it in place. Third, rest the shelf onto the shelf support. Loosen the shelf support to adjust and level.

# Monitor Bracket Instructions

## Extrusion Channel Applications



### EXT-SM-MB

Vesa Pattern: 75 x 75  
up to 200 x 200mm

Max weight varies per application

**Assembled unit:**

10" w x 8.86" h x 2" d  
255mm (w) x 225mm (h) x 50mm (d)

**Shipping dimensions:**

14" l x 6" h x 4" d  
356mm (l) x 152mm (h) x 102mm (d)

**Approximate total shipping weight:**

6 lbs / 3 kg

**Recommended monitor sizes:**

23" - 42"

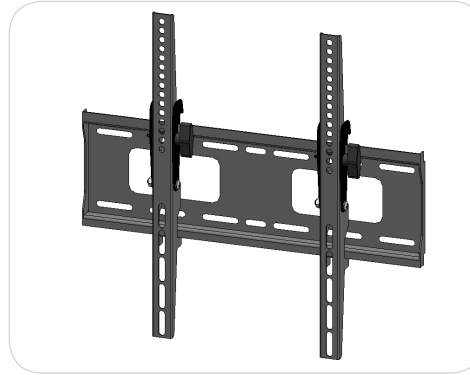

### EXT-M-MB

Vesa Pattern: 200 x 200  
up to 400 x 400mm

Max weight varies per application

**Assembled unit:**

17.6" w x 16.7" h x 1.6" d  
448mm (w) x 425mm (h) x 40mm (d)

**Shipping dimensions:**

24" l x 4" h x 4" d  
610mm (l) x 102mm (h) x 102mm (d)

**Approximate total shipping weight:**

8 lbs / 4 kg

**Recommended monitor sizes:**

32" - 55"

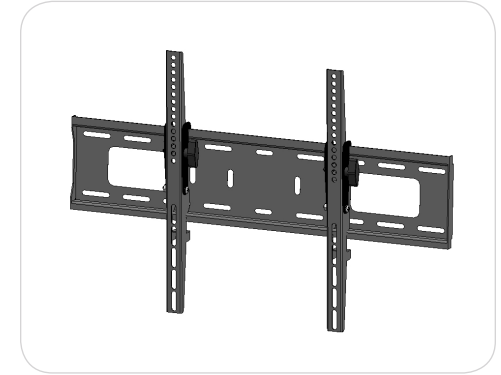

### EXT-LG-MB

Vesa Pattern: 200 x 200  
up to 600 x 400mm

Max weight varies per application

**Assembled unit:**

25.9" w x 16.7" h x 1.6" d  
658mm (w) x 425mm (h) x 40mm (d)

**Shipping dimensions:**

28" l x 6" h x 6" d  
711mm (l) x 152mm (h) x 152mm (d)

**Approximate total shipping weight:**

9 lbs / 5 kg

**Recommended monitor sizes:**

37" - 70"

## Included hardware:



LN-100

x2



M5 x 10

LN-LCD-SCW

x2



1/4"-20 x 1"

BOLT-1

x2

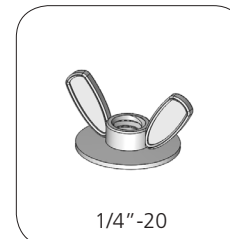

1/4"-20

Flange Wing nut

x2

# Extrusion Connection

## Channel Connection A

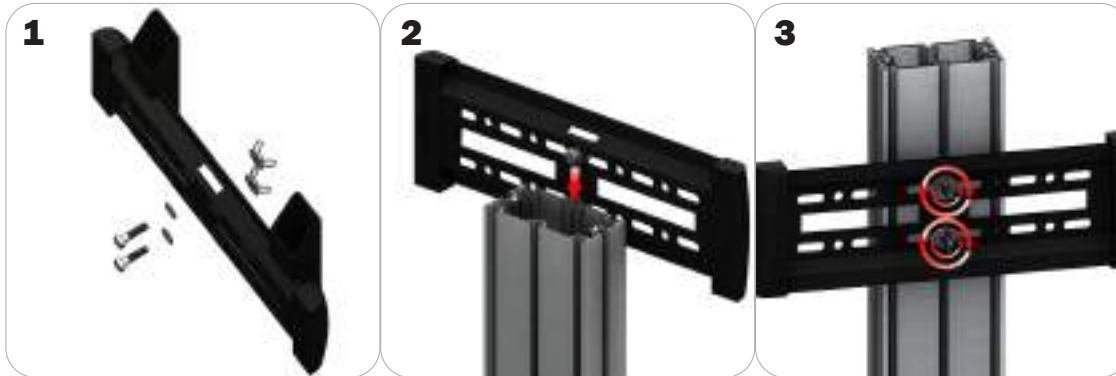

Locate all components needed to assemble the monitor mount with the channel connection A method. You will need (1) monitor bracket, (2) square head bolts, (2) washers, and (2) wing nuts.

**Step 1:** Insert the provided bolts through the washers and center top and bottom holes of the monitor mount. Loosely thread your wing nuts onto the end of the bolts.

**Step 2:** Slide the bolt heads down the extrusion channel.

**Step 3:** Tighten your wing nuts to lock the monitor bracket in place.

**Step 4:** Reference the included manufacturer monitor mount instructions for fastening your monitor to the bracket.

## Channel Connection B

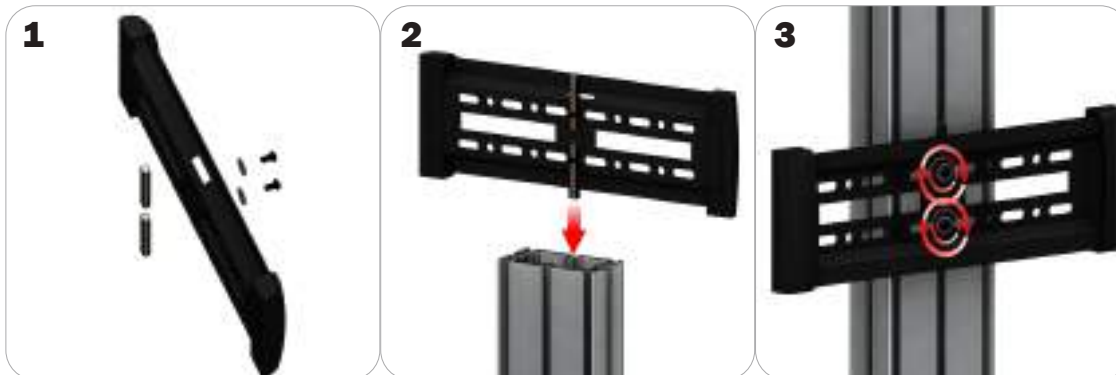

Locate all components needed to assemble the monitor mount with the channel connection B method. You will need (1) monitor bracket, (2) LN-LCD-SCW, (2) LN-100, and (2) washers.

**Step 1:** Loosely thread the LN-LCD-SCW screws through the washers, the center top and bottom holes of the monitor bracket, and through the LN-50 holes.

**Step 2:** Slide the LN-100s down the extrusion channel.

**Step 3:** Tighten your LN-LCD-SCW to lock the monitor bracket in place.

**Step 4:** Reference the included manufacturer monitor mount instructions for fastening your monitor to the bracket.

# Extrusion Connection

## TRI-30MM Channel Tube Connection



Locate all components needed to assemble the monitor mount with the TRI-30MM Channel Tube Connection method. You will need (1) monitor bracket, (2) Square Bolts, and (2) Wingnuts.

**Step 1:** Slip the head of the square bolts into the extrusion channel of the tube.

**Step 2:** Apply your monitor bracket to the protruding square bolts.

**Step 3:** Lock your monitor bracket to the square bolts using the provided wingnuts.

**Step 4:** Reference the included manufacturer monitor mount instructions for fastening your monitor to the bracket.