

# Hybrid Pro 10ft Modular Backwall Kit 21

## HP-K-21

Hybrid Pro™ Modular Kit 21 is a dynamic modular exhibit that features an 8' tall backwall, two sidewalls, six shelves for small product display and a central monitor mount that holds a medium sized monitor. Push-fit SEG fabric graphics that are easy to apply to the backwall and the interior and exterior facing side walls.

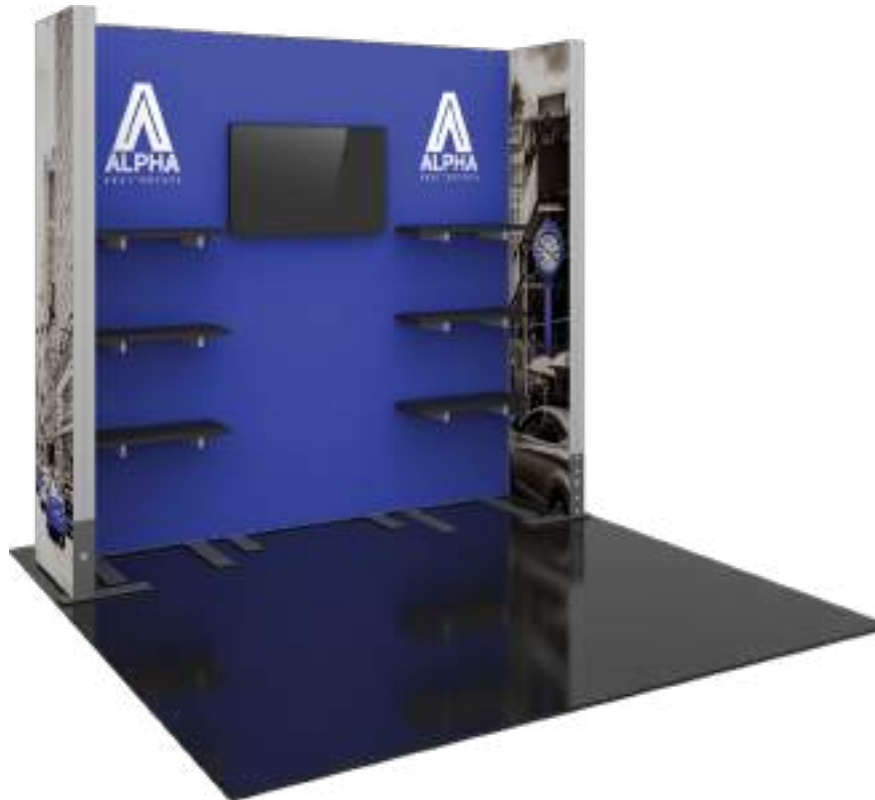

## features and benefits:

- Silver aluminum extrusion frames
- SEG push-fit fabric graphics
- Shelf color options: Silver, Black, Mahogany, Natural
- Medium monitor bracket holds 32-55" LCD\*, max weight: 50 lbs
- Ships freight in a roto-molded protective shipping case
- Lifetime hardware warranty against manufacturer defects

## dimensions:

Hardware

Graphic

Assembled unit:  
118.6" w x 95.45" h x 27.68" d  
2911mm(w) x 2425mm(h) x 704mm(d)

Approximate weight:  
259 lbs / 118 kg

Refer to related graphic template for more information.

Visit:  
<https://www.theexhibitorshandbook.com/download-graphic-templates>

Shipping

## additional information:

Packing case(s):  
SCRATE

Shipping dimensions:  
57" l x 59" h x 33" d  
1448mm(l) x 1498mm(h) x 839mm(d)

Approximate total shipping weight:  
378 lbs / 172 kg

Graphic material:

Dye-sublimation SEG push-fit fabric

When included in a larger kit, a different packaging solution will be listed to accommodate all contents of the kit. Individual packaging no longer provided.

### Tabletop Colors:

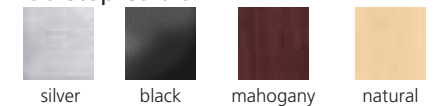

4 person assembly recommended:



This product may include the following materials for recycle:  
aluminum, select wood, fabric, cardboard, paper, steel, and plastics.

We are continually improving and modifying our product range and reserve the right to vary the specifications without prior notice. All dimensions and weights quoted are approximate and we accept no responsibility for variance. E&OE. See Graphic Templates for graphic bleed specifications.

# Included In Your Kit

Tools, Components, & Connectors



ALLEN KEY 5MM x1



CB9 x4



CBE-50 x20

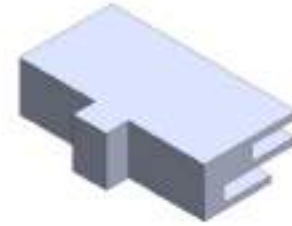

FC-50-SPCR x8



LN114-S2-650 x2



SW-FOOT-650-LN x2

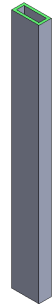

PH4-300-TG x2



PHFC4-800-L-L x2



PHFC4-900-L-L x4

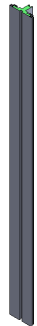

PHFC4-1200-L-MCB9x4



PHFC4-1200 x4

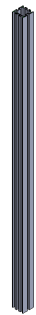

PM2S2-1200-A165-N x4



PM4DSC-600x2



PMFC4-90-1193-A315 x4



CODE x0 PMFC4-90-CAP x4

# Included In Your Kit

Components & Connectors



IB2 x2



CUS-PS2-800-L-L x1



EXT-M-MB x1



PM4S3-MK-SHELF-UNIT x2

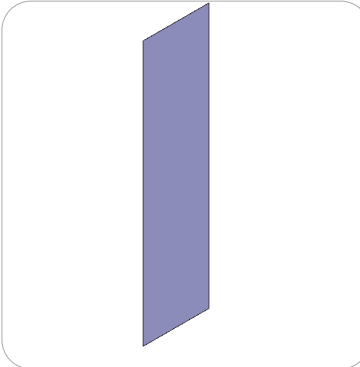

HP-K-21-G-A1

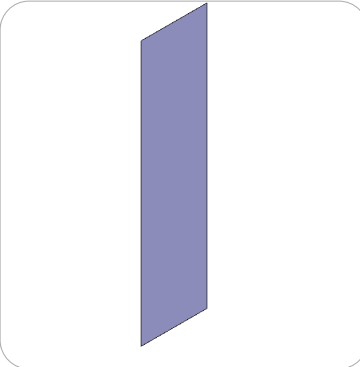

HP-K-21-G-B1



HP-K-21-G-C1

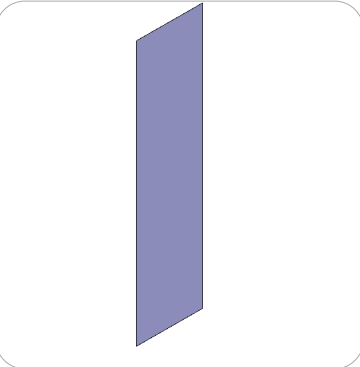

HP-K-21-G-E1

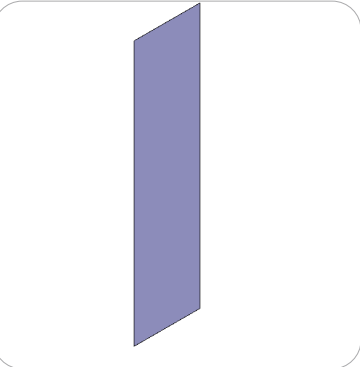

HP-K-21-G-D1

Graphics



HP-K-21-LN-C2

# Labeling Diagram

HP-K-21

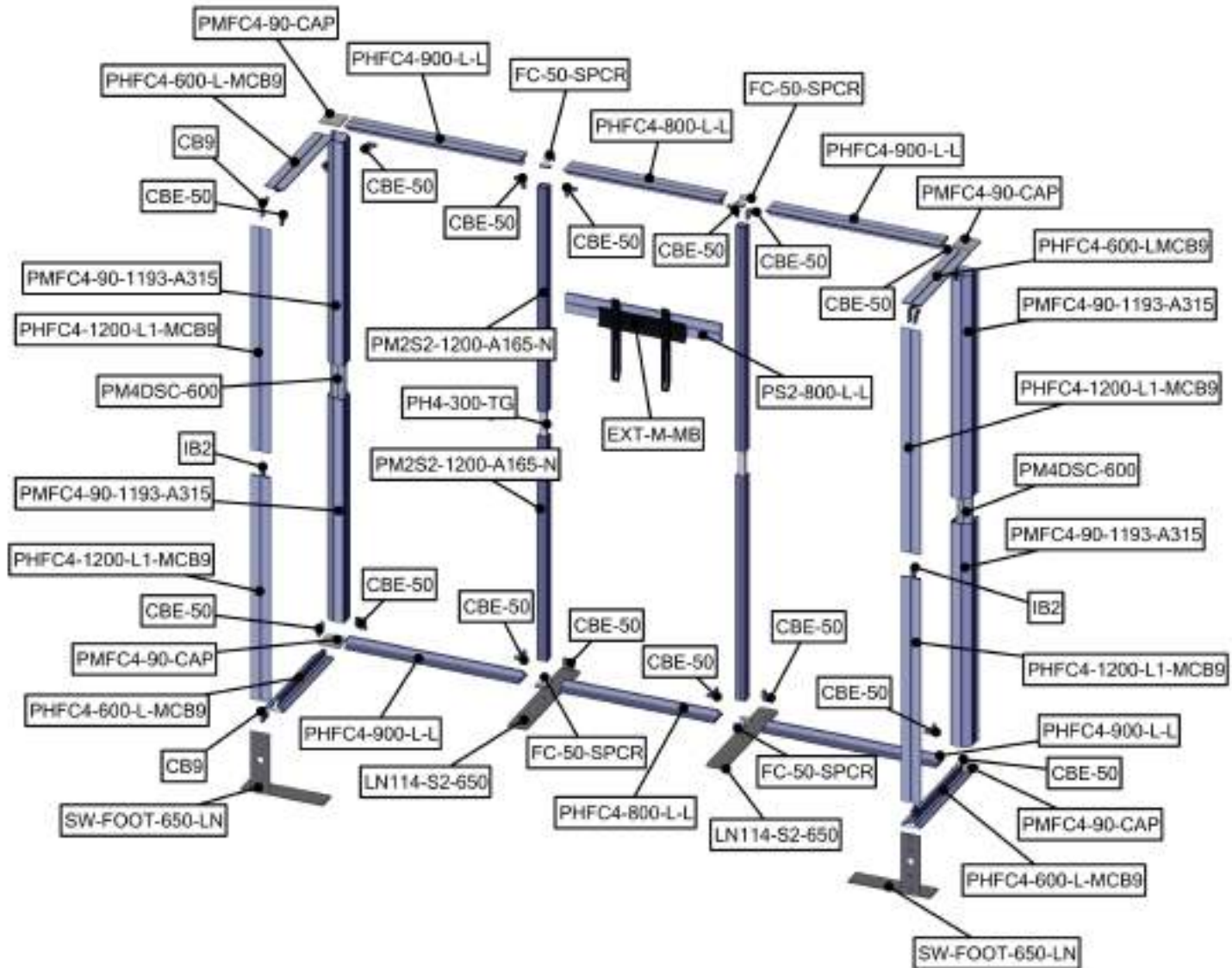

# Exploded Diagram

HP-K-21

Section 1.1

Reference the Suggested Layout page for build location.

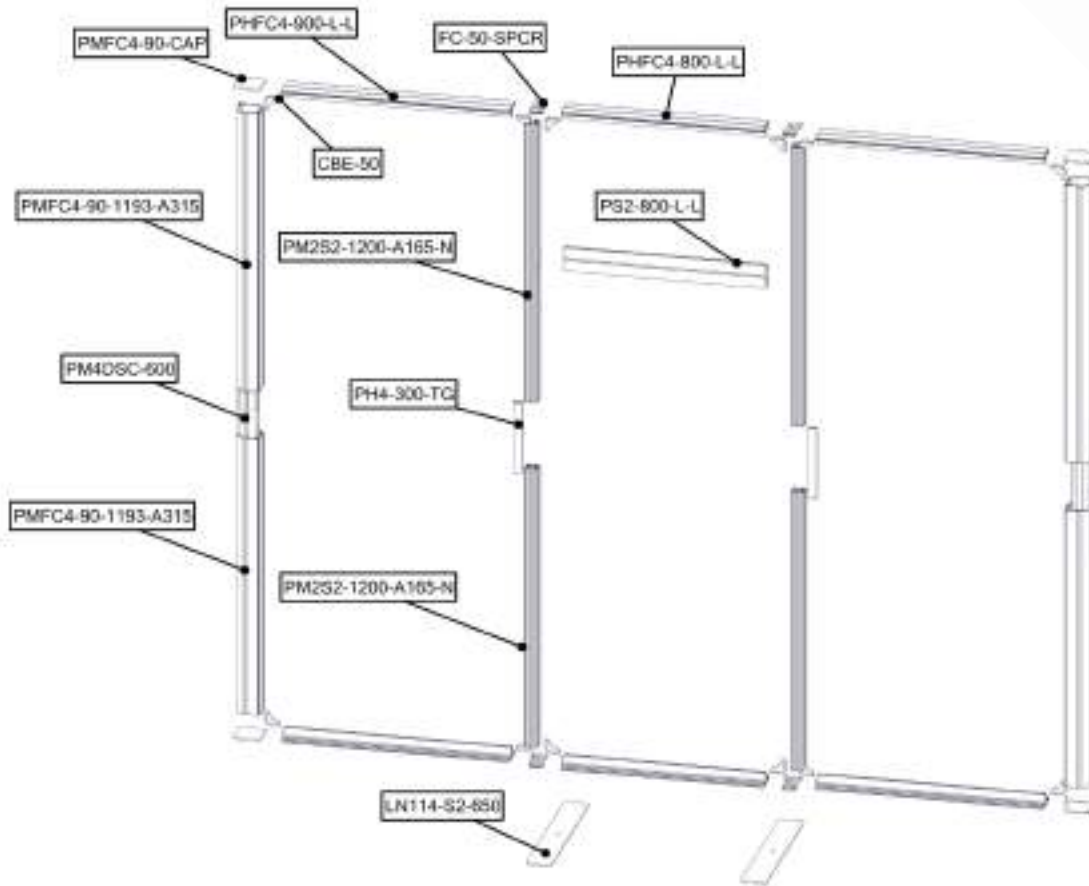

**CENTER FRAME**

# Exploded Diagram

HP-K-21

Section 1.2

Reference the Suggested Layout page for build location.

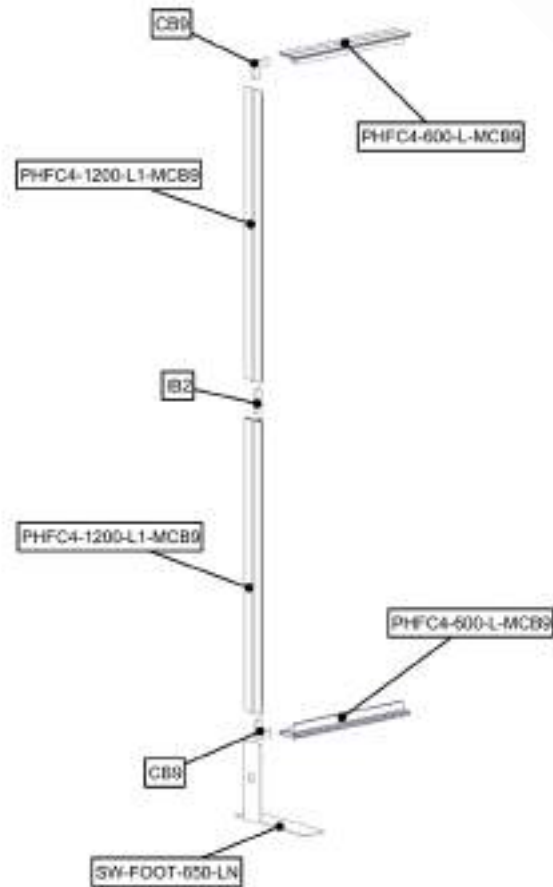

**LEFT SIDE WING**

# Exploded Diagram

HP-K-21

Section 1.3

Reference the Suggested Layout page for build location.

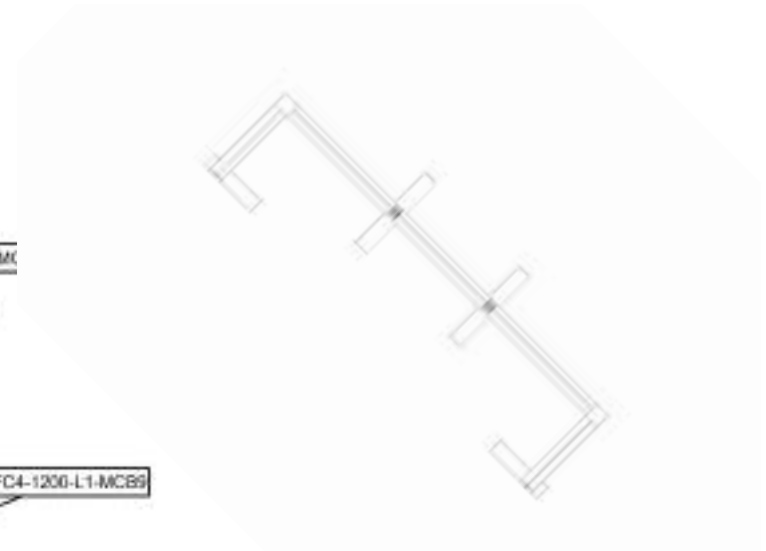
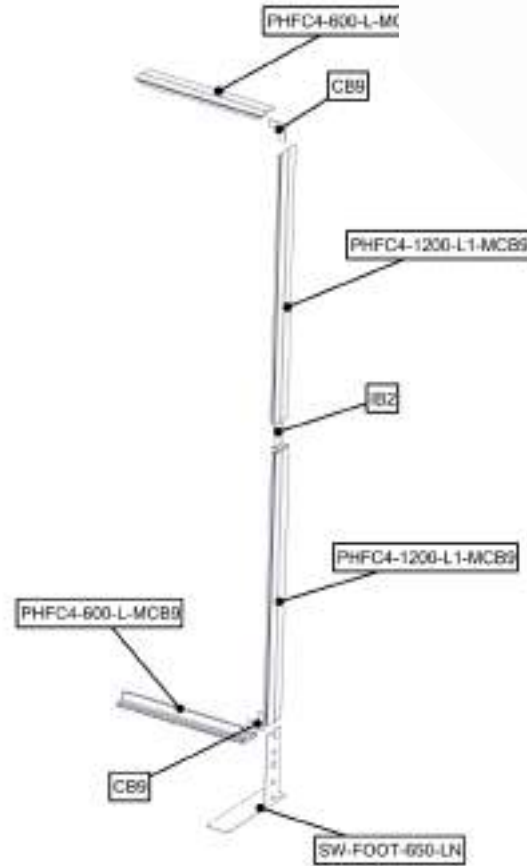

**RIGHT SIDE WING**

# Suggested Kit Layout

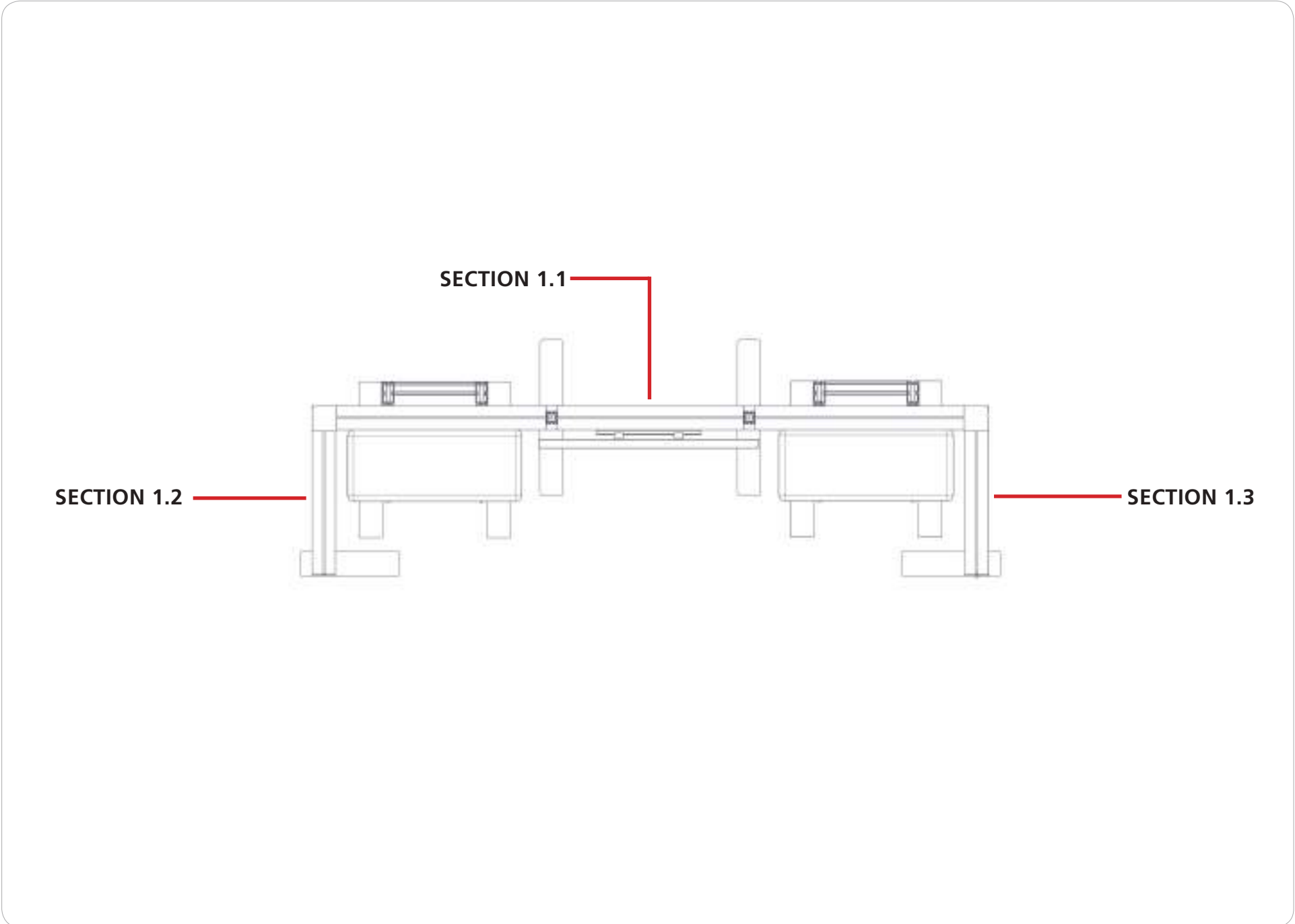



# Kit Assembly

## Step by Step

### Step 1.

Gather the components to build the center frame. Use the Exploded View and the Labeling Diagram for part labels.

Reference Connection Method(s) 1, 2, 3 and 4 for more details.



### Step 2.

Attach CBE-50 & PMFC4-CAP to center frame. Use the Exploded View and the Labeling Diagram for part labels.

Reference Connection Method(s) 6 & 8 for more details.

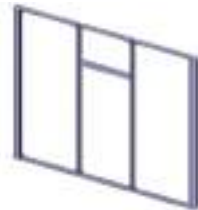

### Step 3.

Attach FC-50-SPCR to center frame. Use the Exploded View and the Labeling Diagram for part labels.

Reference Connection Method(s) 13 for more details.

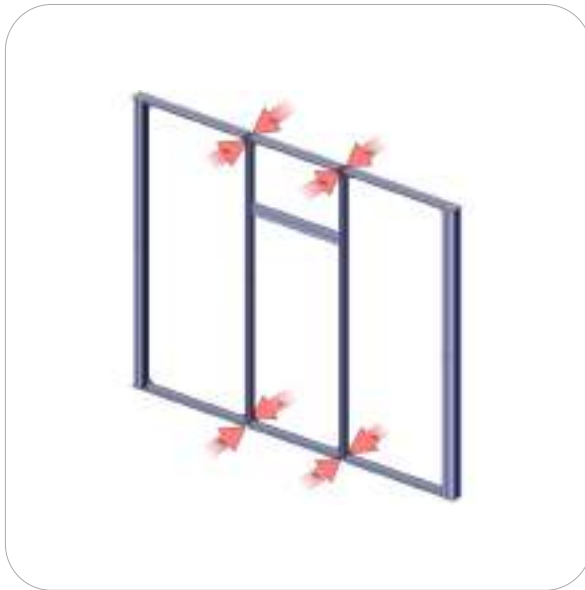

### Step 4.

Gather the components to attach feet to center frame. Use the Exploded View and the Labeling Diagram for part labels.

Reference Connection Method(s) 7 for more details.

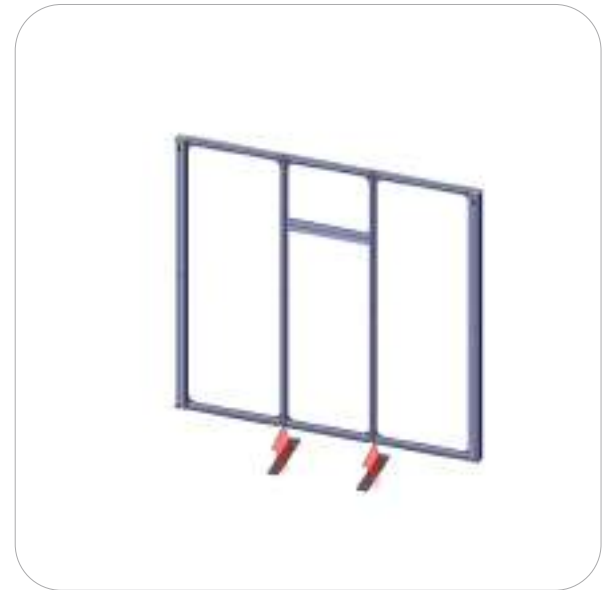
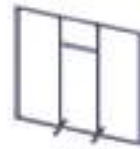

# Kit Assembly

## Step by Step

### Step 5.

Gather the components to build the left wing frame. Use the Exploded View and the Labeling Diagram for part labels.

Reference Connection Method(s) 5, 9, 10 and 11 for more details.



### Step 6.

Gather the components to build the right wing frame. Use the Exploded View and the Labeling Diagram for part labels.

Reference Connection Method(s) 5, 9, 10 and 11 for more details.



### Step 7.

Attach wing graphics. Use the Exploded View and the Labeling Diagram for part labels.

Reference Connection Method(s) 12 for more details.



### Step 8.

Attach center frame graphics. Use the Exploded View and the Labeling Diagram for part labels.

Reference Connection Method(s) 12 for more details.



# Kit Assembly

## Step by Step

### Step 9.

Gather the components to build the 3 shelf kiosk. Use Detailed PDF attach, the Exploded View and the Labeling Diagram for part labels.

Reference Connection Method(s) PDF attached with detailed assembly directions.



Shelves will need to be removed to place kiosk in needed position. See illustration to the right.

### Step 10.

Use the Exploded View and the Labeling Diagram for part labels. To position kiosk in proper position.

Reference Connection Method(s) Move to needed position.



### Step 11.

Attach shelves to proper location needed.

Reference Connection Method(s) PDF attached with detailed assembly directions.



### Step 12.

Attach monitor mount to called out PS2 extrusion. Use the Exploded View and the Labeling Diagram for part labels.

Reference Connection Method(s) 14 for more details.



Setup Complete



# Connection Methods

## Connection Method 1: PMFC4 to PMS2S



First, insert PHFC4 camlock into PMS2S side with one channel. a line the parts to your desired locate. Use tool pictured to lock ,cam lock in place. Be sure not to over tighten, this could cause damage to parts or extrusions.

## Connection Method 2: PM4DSC



First, take the PM4DSC connector and align it with the internal channels of the next extrusion. Second, slide the connector into the inside channels of the extrusion. The tension glides on the connector will keep it center and snug. The extrusion will have stop pins pre installed to stop it from sinking in. Third, take the next extrusion and apply it on top of the connector completing your connection.

## Connection Method 3: PH4SC



First, slide the PH4SC-1 connector into the post unit rests on the PH2C stop. Second, then slide the top post onto the PH4SC-1 connector

## Connection Method 4: PS2 TO PMS2S



First, insert PS2 camlock into PMS2S side with one channel. a line the parts to your desired locate. Use tool pictured to lock ,cam lock in place. Be sure not to over tighten, this could cause damage to parts or extrusions.

# Connection Methods

## Connection Method 5: PMFC4-90 to PHFC4

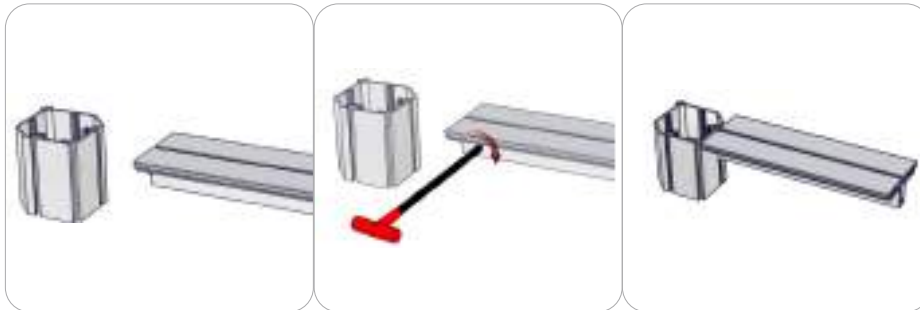

First, insert PMFC4 camlock into PMFC4-90. Align the parts to your desired location. Use the tool pictured to lock the camlock in place. Be sure not to over-tighten, as this could cause damage to parts or extrusions.

## Connection Method 6: PMFC4-90-CAP



First, match up the plastic clips on the cap to the shape of the extrusion. Second, just slide the cap into position.

## Connection Method 7: LN114-S2-650

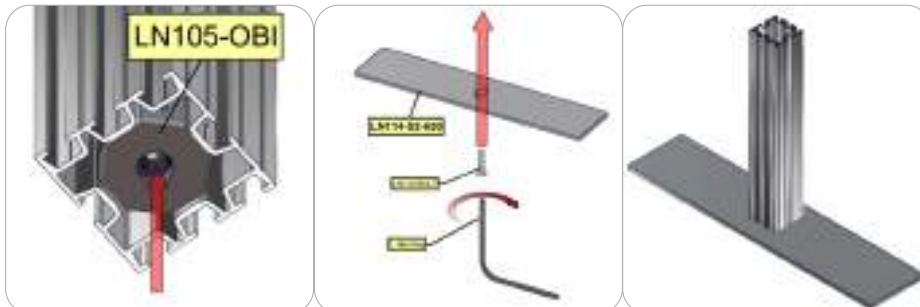

First, with the cam lock disengaged, place the cam lock teeth into the extrusion channel. Second, use the allen key tool to lock it in place. Make half turns clockwise to engage the cam lock. Do not over-tighten the lock buttons.

## Connection Method 8: CBE-50

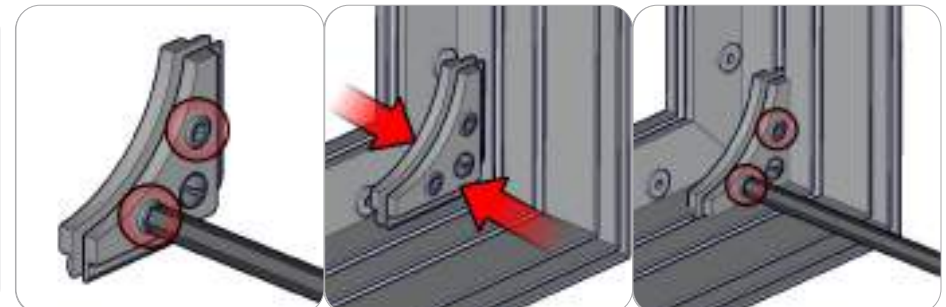

First, use the provided hex tool to loosen the two 5mm hex set screws. Next, compress the bracket and apply it to the corner channel. Then, tighten the set screws. Do not over-tighten the set screws. Do not loosen the spring-loaded screw.

# Connection Methods

## Connection Method 9: IB2



First, insert the in-line connector into the extrusion while holding in the lock button. Then, slide the next extrusion onto the same in-line connector again holding in the lock button. Finally, use the provided allen key to lock the in-line connector in place. Use the allen key tool to turn the lock buttons, make quarter turns and do not over tighten the lock buttons.

## Connection Method 10: CB9



First, insert the corner connector into the extrusion while holding in the lock button. Then, slide the next extrusion onto the same corner connector again holding in the lock button. Finally, use the provided allen key to lock the corner connector in place. Use the allen key tool to press the lock buttons, make quarter turns and do not over tighten the lock buttons.

## Connection Method 11: SW-FOOT-650

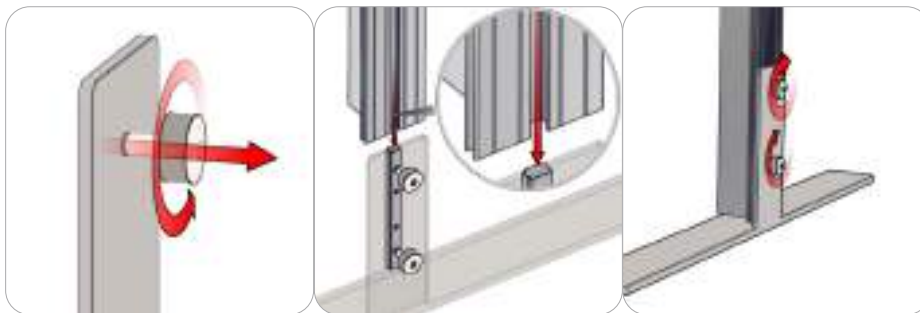

First, loosen the thumb screws and channel bars on the stabilizing bases. Do not disassemble them. Second, slide channel bars into the frame channel flush with the base of the frame. Finally, tighten the thumb screws and channel bars securing the attachment.

## Connection Method 12: Graphic Application

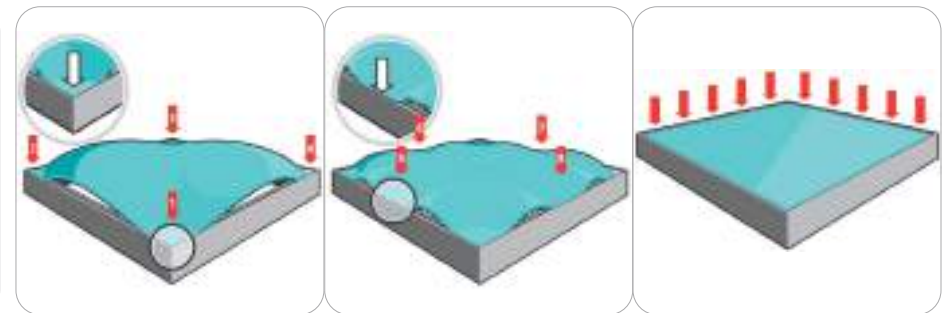

First, insert the silicone edge frame corners into the frame graphic channel (points 1 through 4). Second, insert the silicone edge frame sides into the frame graphic channel (points 5 through 8). Third, push the remaining silicone edge fabric into the frame graphic channel. Similar setup is recommended for the opaque liner. To remove these panels, simply pull the loop tag sewn near a corner.

# Connection Methods

## Connection Method 13: FC-50-SPCR

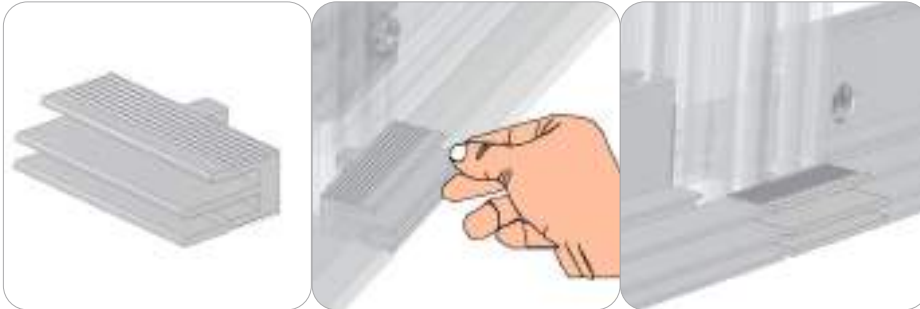

First, insert the spacer in the center channel of the PM2S2. This will cover the space of the void between both PHFC4 extrusions. Second, move to the desired position needed.

## Connection Method 14: EXT-M-MB



First, attach plate to PS2 using carriage bolts and wing nuts. Second, follow the illustration above on how to connect TV arms. Last, once arms are attached and fixed correctly, then remove them. It is recommended you attach arms to the back of the MONITOR before installing.

# Freestanding Monitor Kiosk

PM4S3-MK-M  
PM4S3-MK-L

PM4S3-MK-M-MSHELF  
PM4S3-MK-L-MSHELF

PM4S3-MK-SHELF-UNIT

The Freestanding Monitor Kiosk is a superior multimedia display that can be used for multiple applications, as well as in trade show exhibits and for events. Kiosks include monitor mounts to support a medium or large size TV, and a corresponding medium or large shelf may be added. Monitor mounts support TV's up to 40 lbs and 32" - 70" in size, and can be adjusted to the perfect height; an included shelf can hold up to 15 lbs. The Shelf Unit is a great addition that proudly displays small products. Install the Freestanding line behind a fabric backwall for a truly impressive display.

Freestanding Monitor Kiosk



PM4S3-MK-M  
PM4S3-MK-L

Freestanding Monitor Kiosk with Shelf



PM4S3-MK-M-MSHELF  
PM4S3-MK-L-MSHELF

Freestanding Shelf Unit



PM4S3-MK-SHELF-UNIT

## features and benefits:

- Premium aluminum extrusion frames with cam lock and tension glide assembly
- Easy to store and ship
- Quick to set up
- Weighted feet for added stability
- Kits may include: a medium or large monitor mount, shelf, or combination
- Choice of medium or large monitor mount options. (Freestanding Monitor Kiosk with Shelf or Freestanding Shelf)
- Lifetime limited hardware warranty against manufacturer defects

## dimensions:

### Hardware

Assembled unit (no shelf):  
25.59" w x 70.98" h x 25.59" d  
650mm(w) x 1803mm(h) x 650mm(d)

Assembled unit (with shelf):  
29.53" w x 70.98" h x 25.59" d  
751mm(w) x 1803mm(h) x 650mm(d)

Approximate weight:  
(excludes cases & monitor mount)

40 lbs / 19 kg

Add 10 lbs / 5 kg for each shelf

## additional information:

-Medium monitor mount can hold 37-70" monitor/ max weight 40 lbs

-Large monitor mount can hold 40"-65" monitor/ max weight 40 lbs

-Monitor not included

-Shelf can hold suggested max weight: 15 lbs

-If shipping with backwall kit cases may vary

### Shipping

Packing case(s):  
1 OCE Case

Shipping dimensions:  
OCE: Expandable case length (l) may vary  
40" - 66" l x 18" h x 18" d  
1016mm-1677mm(l) x 458mm(h) x 458mm(d)

Approximate total shipping weight:  
Monitor Kiosk:  
(Case & monitor mount)  
Medium  
83 lbs / 38 kg  
Large  
85 lbs / 39 kg

Monitor Kiosk with Shelf:  
(Case, monitor mount, & shelf)  
Medium  
93 lbs / 43 kg  
Large  
95 lbs / 44 kg

Shelf Unit:  
(Case & shelves)  
116 lbs / 53 kg

We are continually improving and modifying our product range and reserve the right to vary the specifications without prior notice. All dimensions and weights quoted are approximate and we accept no responsibility for variance. E&OE. See Graphic Templates for graphic bleed specifications.



# Included In Your Freestanding Monitor Kiosk

Tools, Components, Connectors & Extrusions



5MM ALLEN-T x1

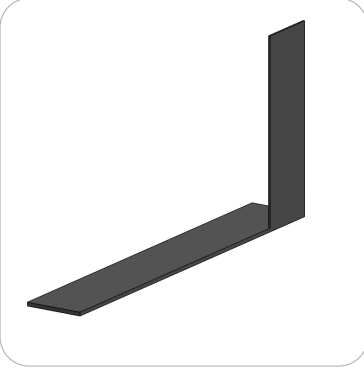

PM4S3-MM-FOOT-L x1



PM4S3-MM-FOOT-R x1



LN100 x6

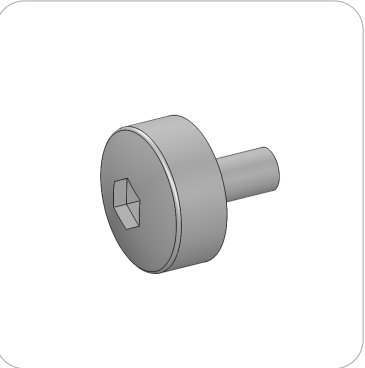

M5 THUMBSCREW x8



PH2-350-L-L x3



PH5-100-L-L x2



PM4S4-150 x2



PM4S3-600-A165-A165 x2



PM4S3-1200-A165-A165 x2



PH2-300-TG x2



EXT-M-MB (or) EXT-LG-MB x1  
Fastening Hardware Included



CBE-50 x2



# Included In Your Freestanding Monitor Kiosk with Shelf

Tools, Components, Connectors & Extrusions



5MM ALLEN-T x1

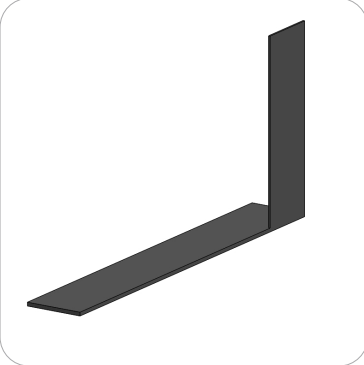

PM4S3-MM-FOOT-L x1



PM4S3-MM-FOOT-R x1



LN100 x6

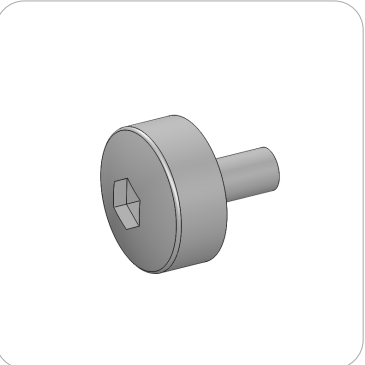

M5 THUMBSCREW x8



PH2-350-L-L x3



PH5-100-L-L x2



PM4S4-150 x2



PM4S3-600-A165-A165 x2



PM4S3-1200-A165-A165 x2



PH2-300-TG x2



EXT-M-MB (or) EXT-LG-MB x1  
Fastening Hardware Included



CBE-50 x4



# Included In Your Freestanding Monitor Kiosk with Shelf

Components, Connectors & Extrusions



PH-400-L-SIDE-MK x2

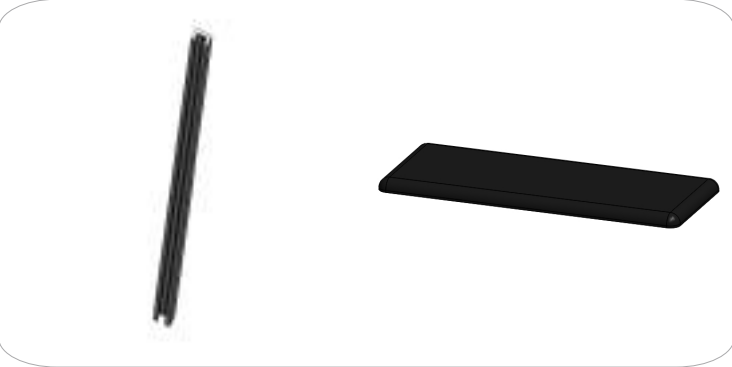

PE-1200 x2  
\*will ship preattached to shelf



CT21-MK-SHELF x1



LN605-EN x2



# Included In Your Freestanding Shelf

Tools, Components, Connectors & Extrusions



5MM ALLEN-T x1

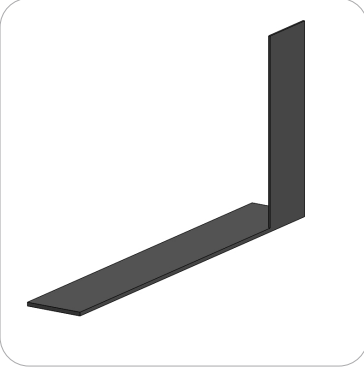

PM4S3-MM-FOOT-L x1



PM4S3-MM-FOOT-R x1



LN100 x6

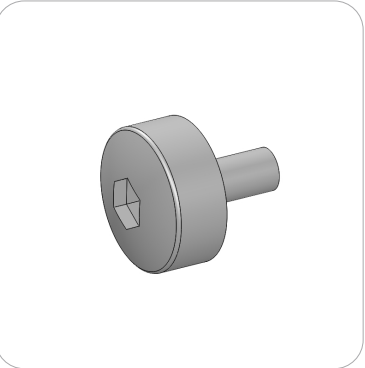

M5 THUMBSCREW x8



PH2-350-L-L x3



PM4S3-600-A165-A165 x2



PM4S3-1200-A165-A165 x2



PH2-300-TG x2



PH-400-L-SIDE-MK x6



PE-1200 x6  
\*will ship preattached to shelf



CT21-MK-SHELF x3



LN605-EN x6



# Exploded View

## PM4S3-MK-M PM4S3-MK-L

Please note:  
This is the kiosk frame build for  
either medium or large kit.

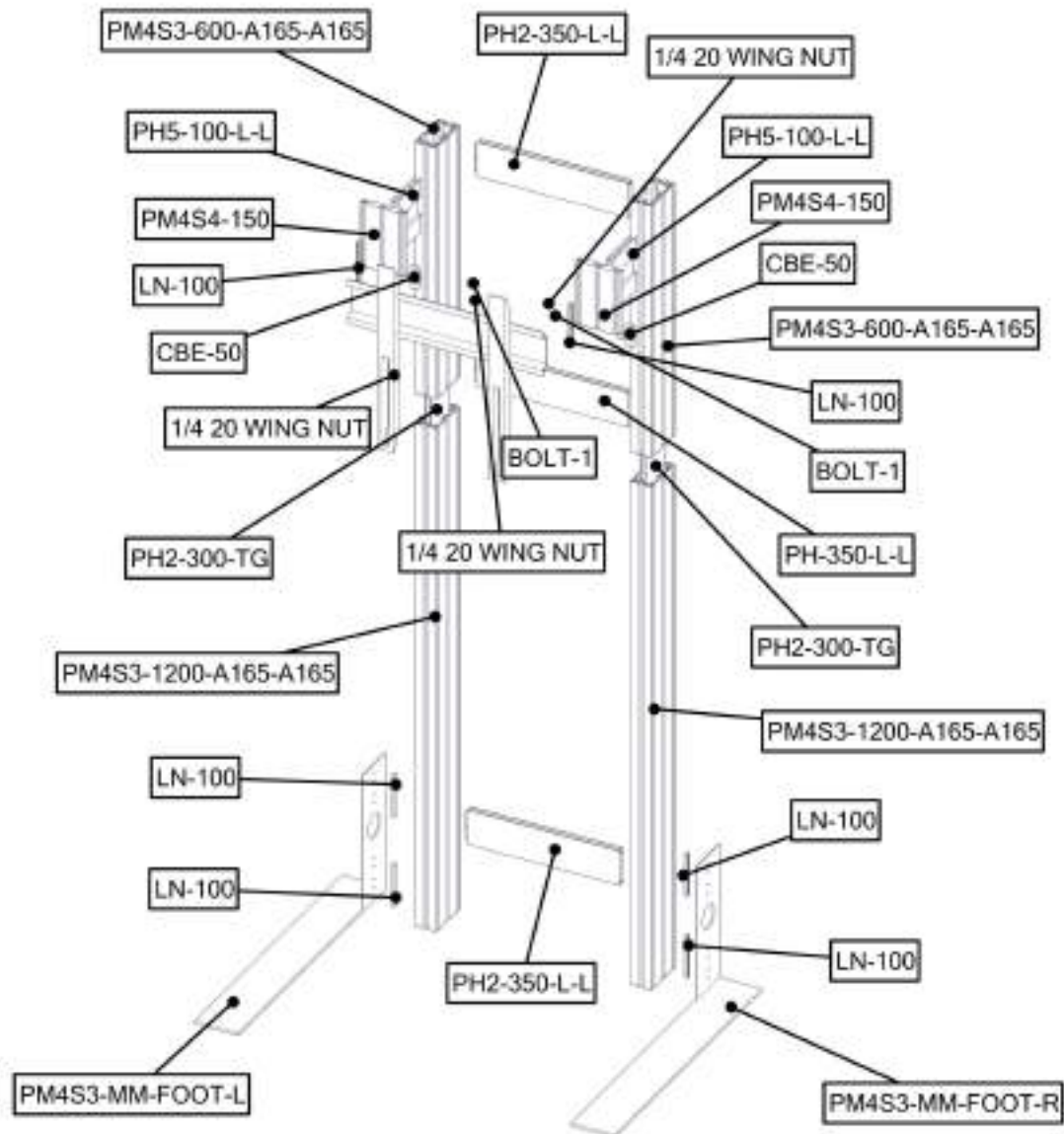

# Exploded View

## PM4S3-MK-M-MSHELF PM4S3-MK-L-MSHELF

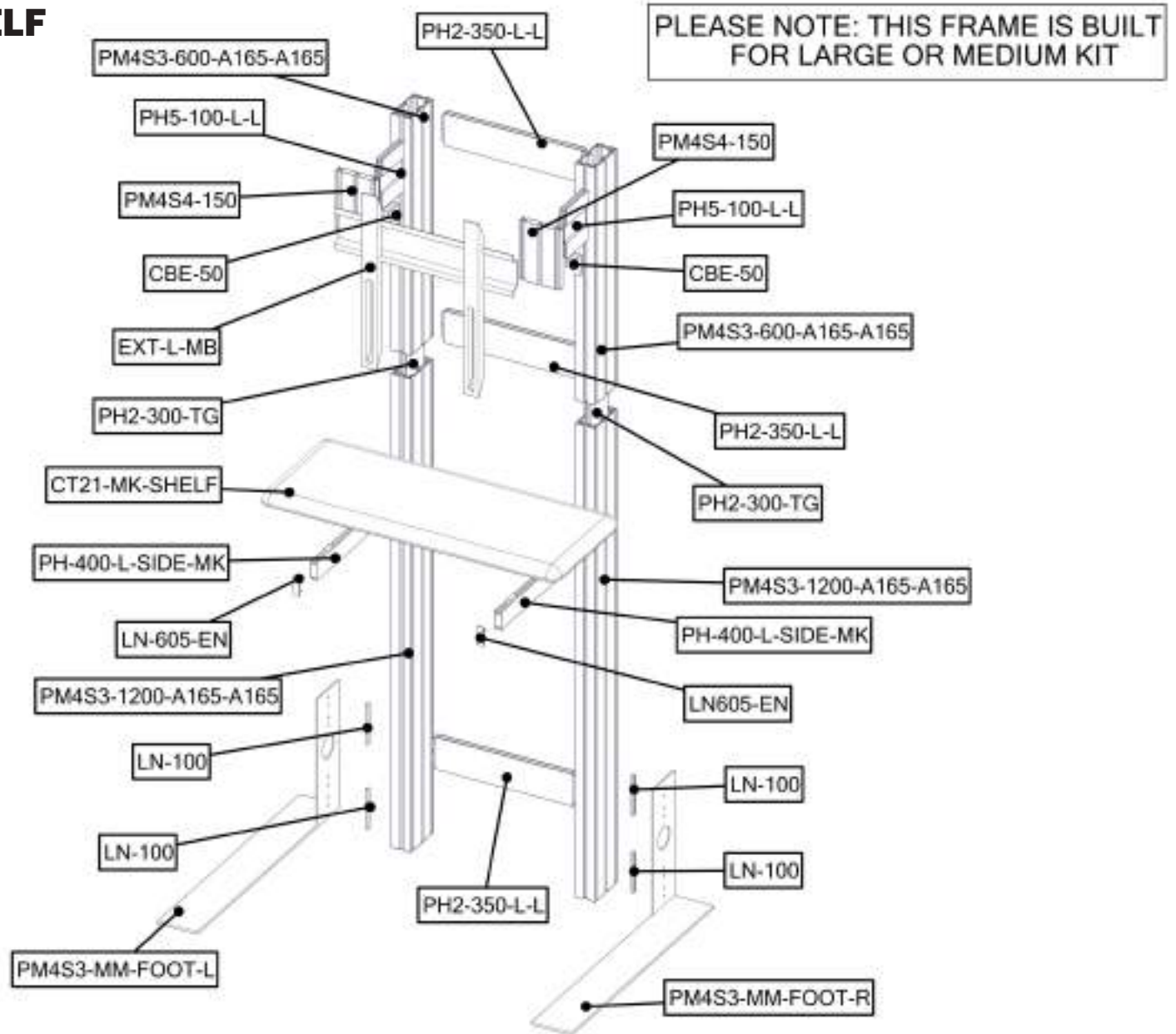

# Exploded View

## PM4S3-MK-SHELF-UNIT

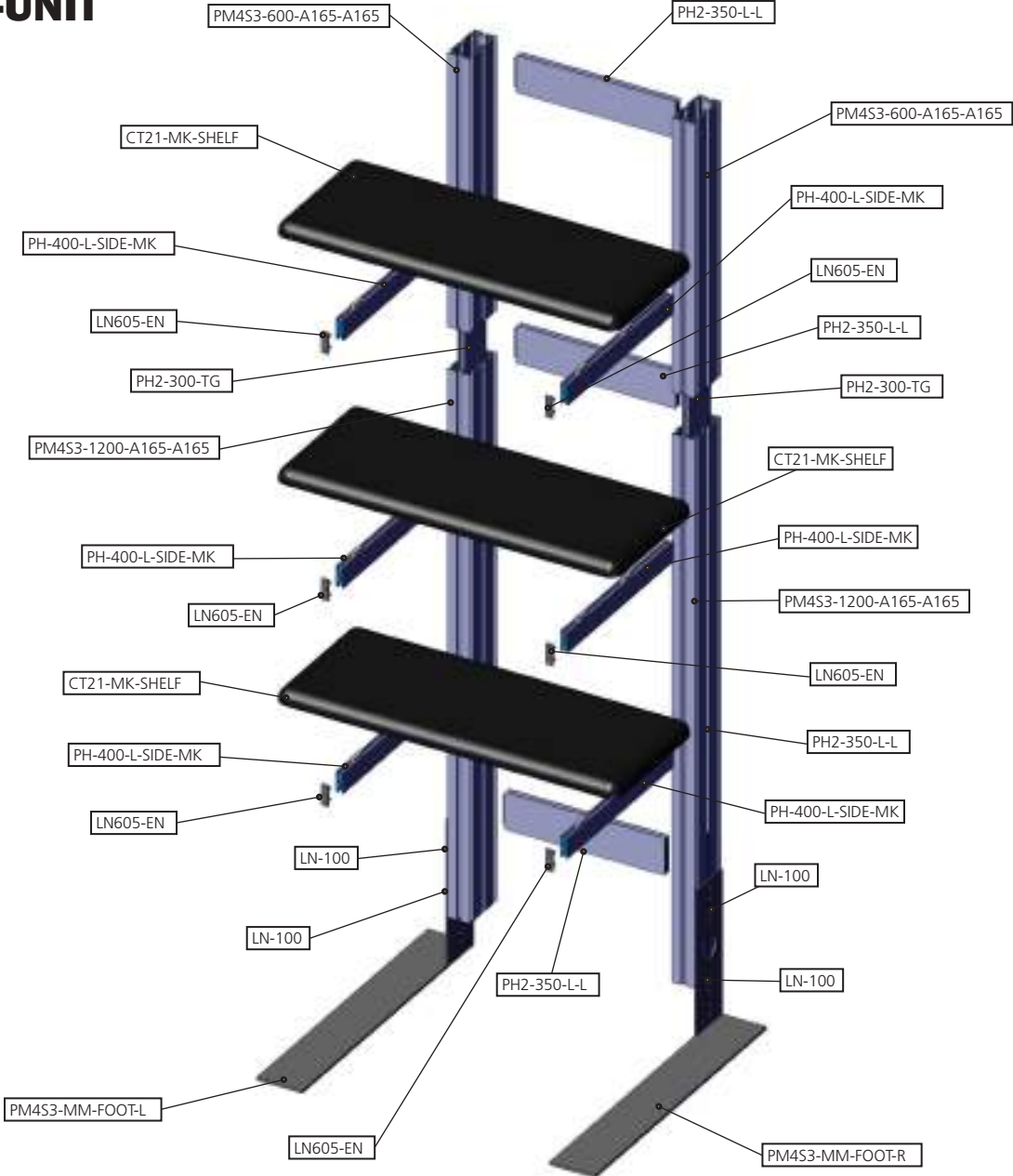

# Kit Assembly

## Step by Step

### Step 1.

Reference the image to the right. Locate the coded extrusions. Slide the PH2-300-TG connector into one end of the PM4S3-1200-A165-A165 so that it goes as deep as the internal pins. Connect the PM4S3-600-A165-A165 by sliding it over the PH2-300-TG. Repeat for this step for the second vertical.

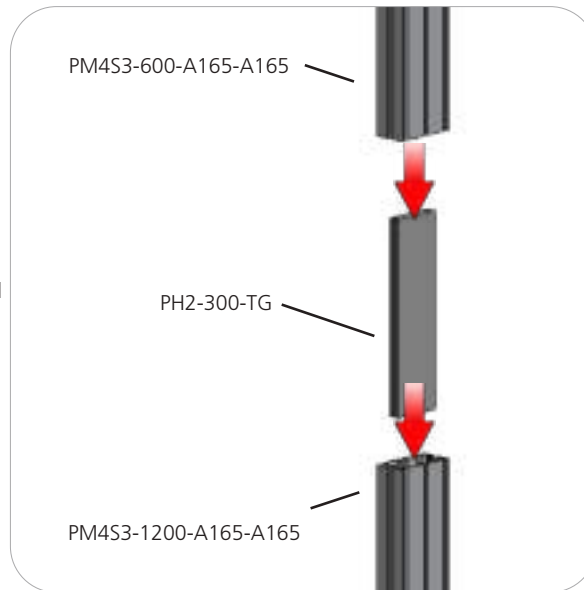

### Step 2.

Collect your extrusions and handtool. Using the provided handtool, lock the extrusions into the back channel of the three channel PM4S3 faces as shown in the image below. Be sure the locks face toward the back of the assembly and do not over tighten.

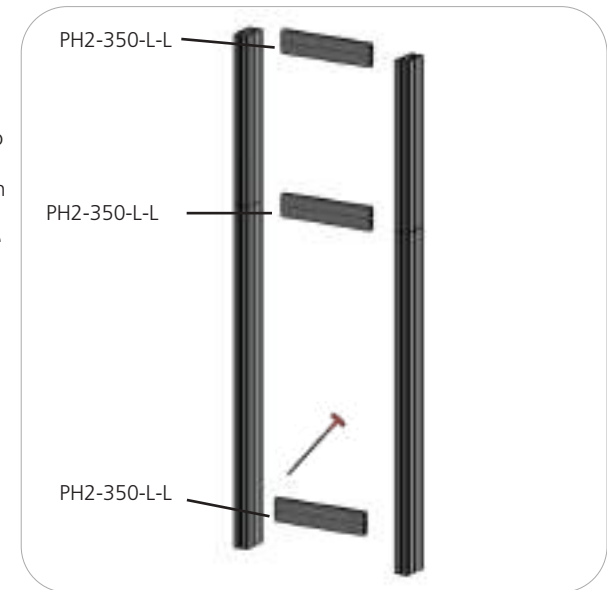

### Step 3.

Locate the M5 thumbscrews, LN100s, and the PM4S3-MM stabilizing bases. Slide the LN100s into the middle channel of the PM4S3. Hand screw the M5 thumbscrews through the base holes and into the LN100 holes. Use the handtool to securely fasten the M5 Thumbscrews. Do not over tighten.

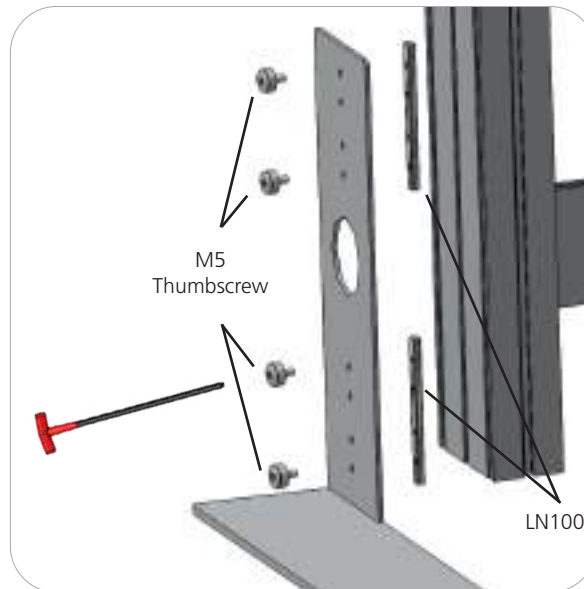

### STOP

Orbus recommends that you move your kiosk(s) in place before continuing on with the rest of assembly.

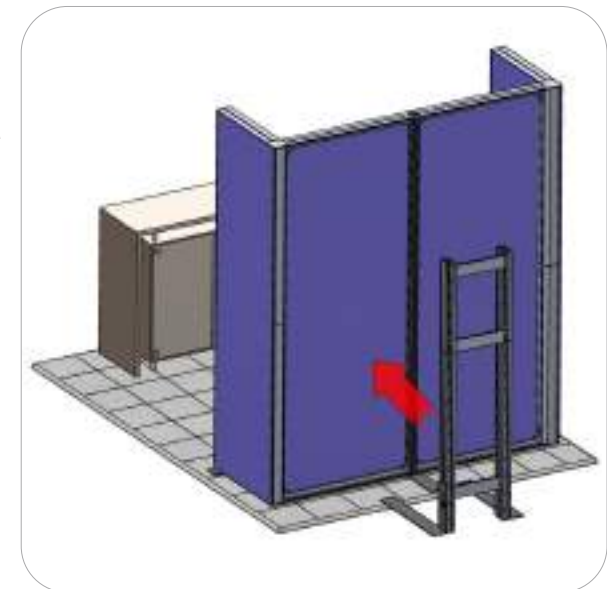



# Kit Assembly

## Step by Step - Monitor Mount

### Step 4.

This step is for kiosks with monitor mounts. Skip to step 7 for shelf kiosks.

Measure from the ground to the center of the hole in your main kit's graphic. Lock the center of your PH5-100-L-L into the PM4S3 stacks at the dimension height of the graphic hole, ADD CBE-50 for support under PH5. Do not over tighten.

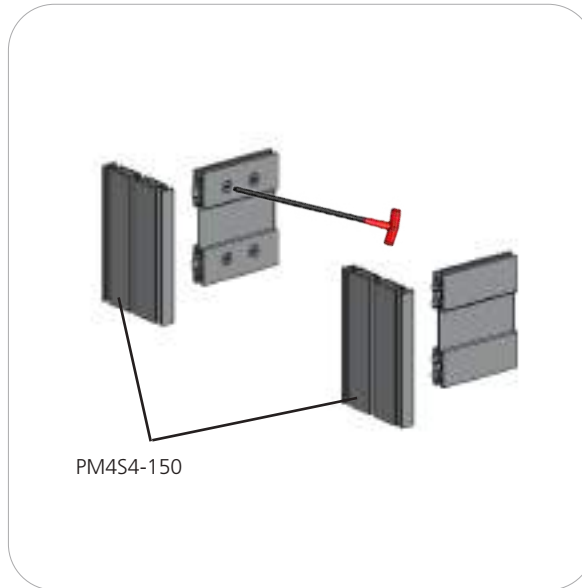

### Step 5.

NOTE: Your main backwall assembly must be completed with graphics before completing this step of the monitor kit.

Lock your PM4S4-150 to the ends of the PH5-100-L-L. Do not over tighten.

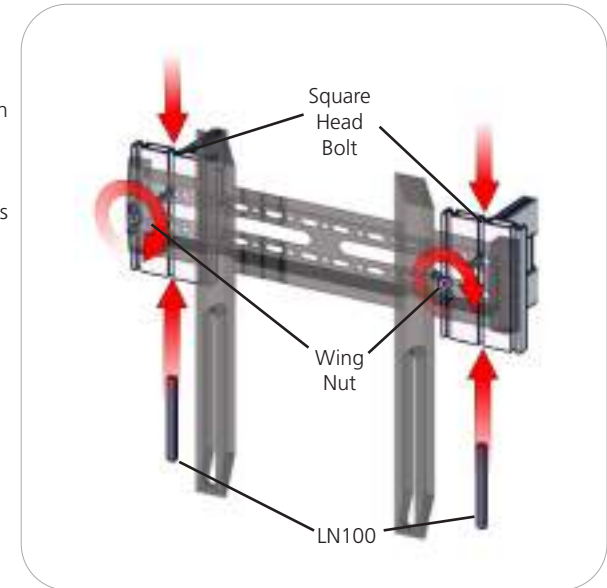

### Step 6.

Set your monitor stand so that the extrusion arms fit through the graphic hole. Use the provided fastening hardware to complete your monitor stand. Slide the LN100 into the bottom center channel of the PM4S4-150. Next, slide the Square Head Bolt into the top center channel of the PM4S4-150. Apply the monitor bracket and spacer washer before fastening with the wingnut. Monitor mount may vary depending on size. Monitor not included.

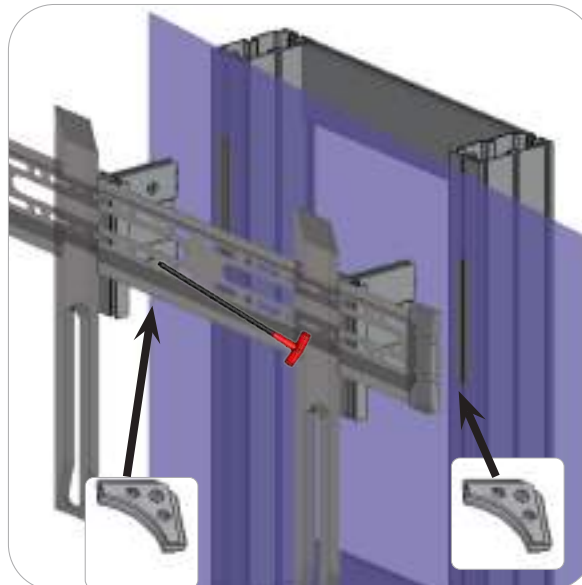

**ATTACH CBE-50 UNDER PH5 FOR SUPPORT**

# Kit Assembly

## Step by Step - Shelf

### Step 7.

Insert the LN605-EN end caps. Lock the CT21-MK-SHELF to the PH-400-L-SIDE-MK. Do not over tighten.

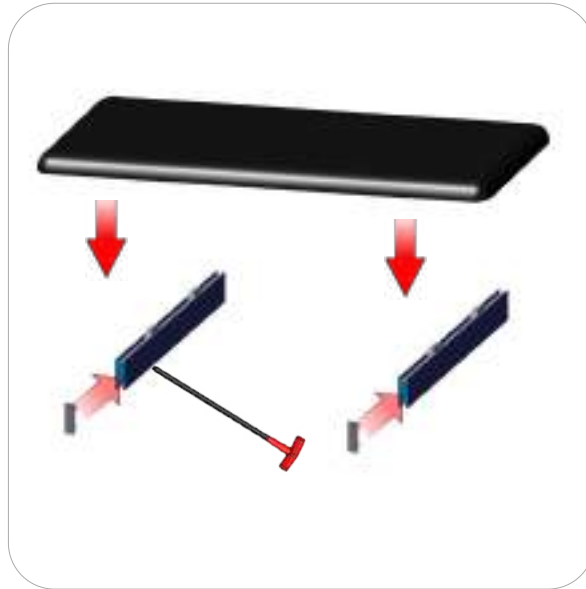

### Step 8.

Lock your PH-400-L-SIDE-MK into the PM453 stacks at the desired dimension height. Do not over tighten.

Refer to the attached supplemental sheet for details on shelf height(s).

Setup is complete.

Repeat steps 7 and 8 twice more for Shelf Unit.



# Freestanding Display Shelf

## PM4S3-MK-SHELF

Freestanding display shelves are easily attached to your assembled kiosk for displaying promotional materials. This shelf can be added to a Freestanding Monitor Kiosk order.



### features and benefits:

- Premium aluminum extrusion frames with cam lock and tension glide assembly
- Easy to store and ship
- Quick to set up
- Lifetime limited hardware warranty against manufacturer defects
- Great for display opportunities

### dimensions:

Hardware	Shipping
<p>Assembled unit: Medium or Large</p> <p>29.53" w x 6.35" h x 15.87" d 751mm(w) x 162mm(h) x 404mm(d)</p> <p>Approximate weight (shelf): 10 lbs / 5 kg</p>	<p>Ships in box</p> <p>Shipping dimensions: Special order - 30" (l) x 16" (h) x 4" (d) 762mm(l) x 407mm(h) x 102mm(d)</p> <p>Approximate total shipping weight: 12 lbs / 6 kg</p>
additional information:	
<p>-Shelf can hold suggested max weight 15 lbs</p> <p>-If shipping with backwall kit cases may vary</p>	

We are continually improving and modifying our product range and reserve the right to vary the specifications without prior notice. All dimensions and weights quoted are approximate and we accept no responsibility for variance. E&OE. See Graphic Templates for graphic bleed specifications.

# Included In Your Freestanding Display Shelf

Components, Connectors & Extrusions



PH-400-L-SIDE-MK x2



PE-1200 x2  
\*will ship preattached to shelf



CT21-MK-SHELF x1

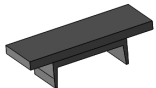

LN605-EN x2



# Exploded View

## PM4S3-MK-SHELF

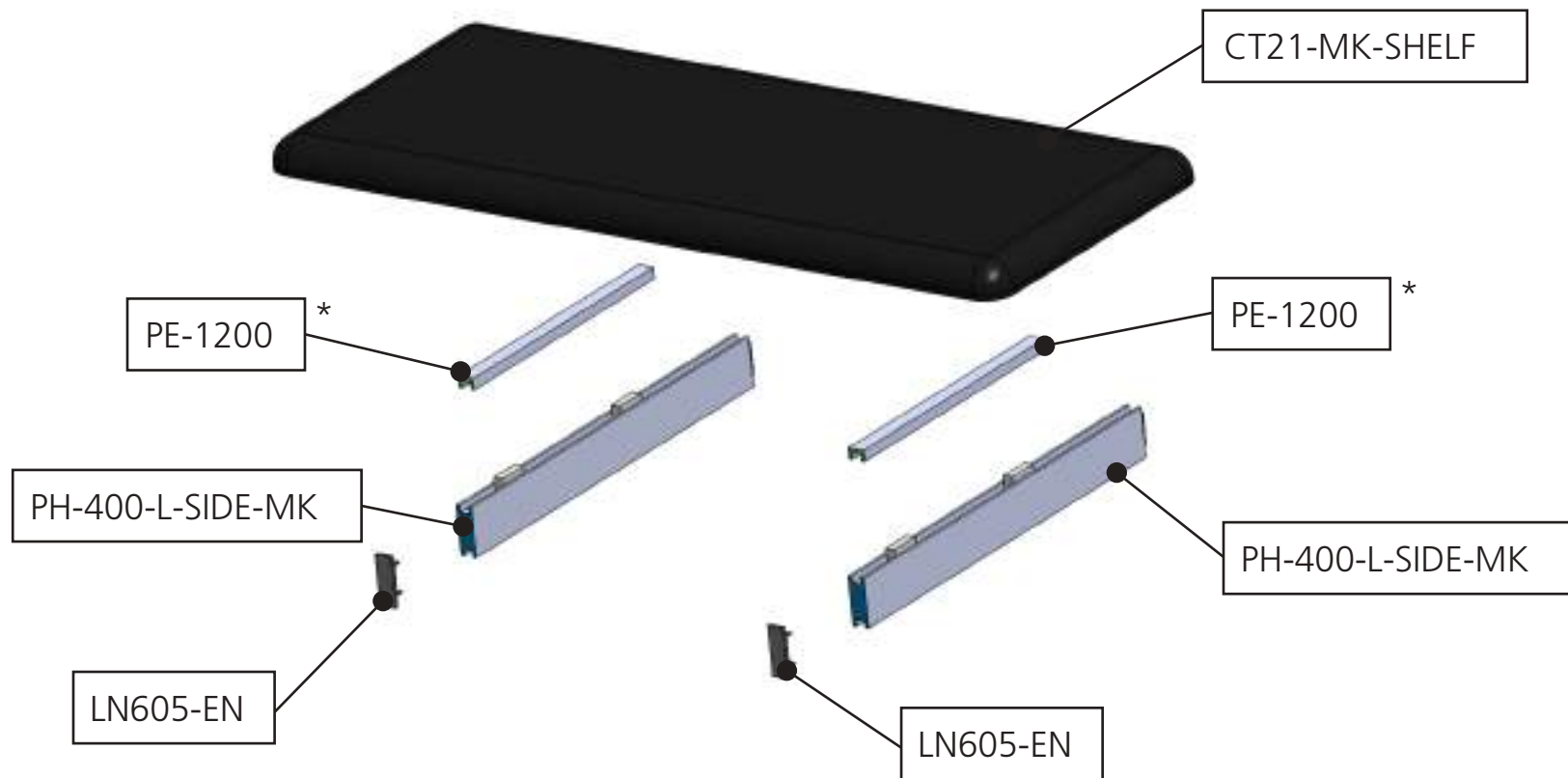

\*Note: PE will ship preattached to shelf

# Kit Assembly

## Step by Step - Shelf

### Step 8.

Insert the LN605-EN end caps. Lock the CT21-MK-SHELF to the PH-400-L-SIDE-MK. Do not over tighten.

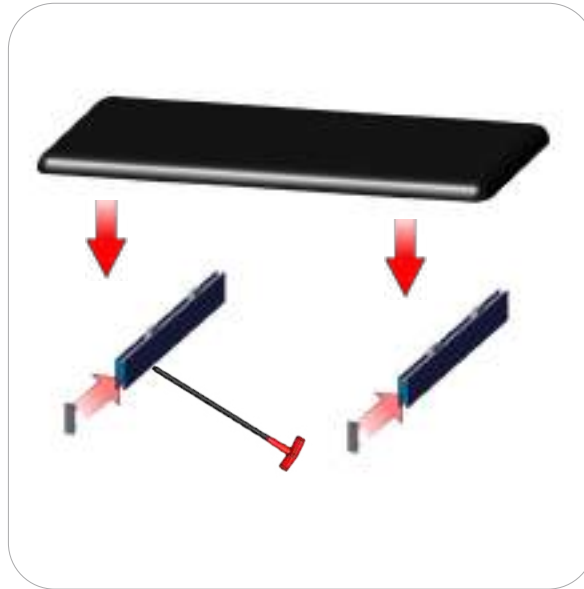

### Step 7.

Lock your PH-400-L-SIDE-MK into the PM453 stacks at the desired dimension height. Do not over tighten.

Refer to the attached supplemental sheet for details on shelf height(s).

Setup is complete.

Repeat steps 7 and 8 twice more for Shelf Unit.



Location of vinyl adhesive tape  
Tape color-**CLEAR**

Indicator shown in green to show detail



**TORQUATA**  
**Self-Adhesive Measuring**  
**Tape**



Note: tape comes preattached to extrusion,  
0" starts from the bottom (at the floor)

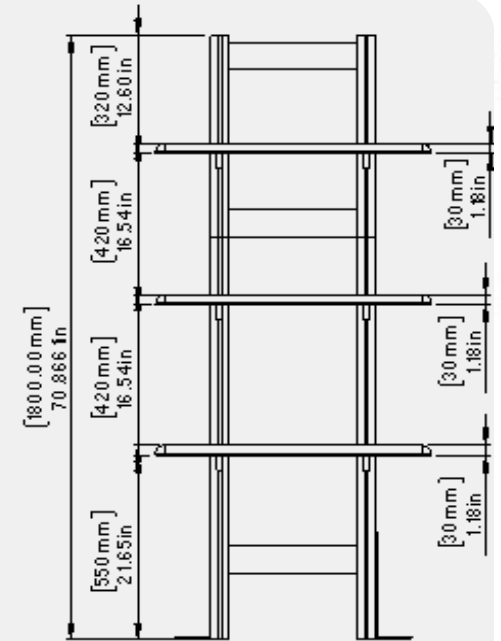
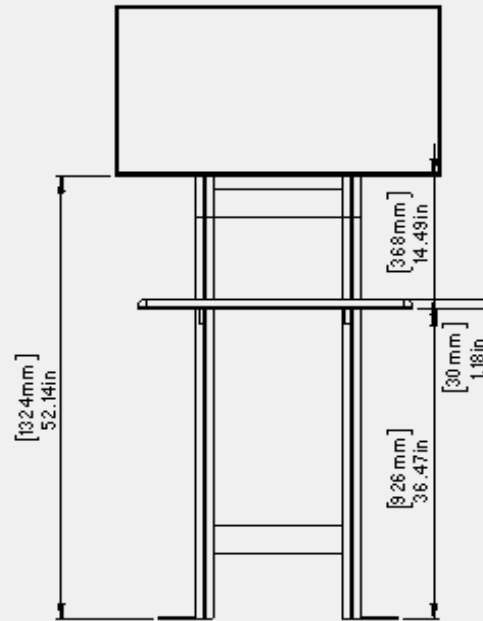
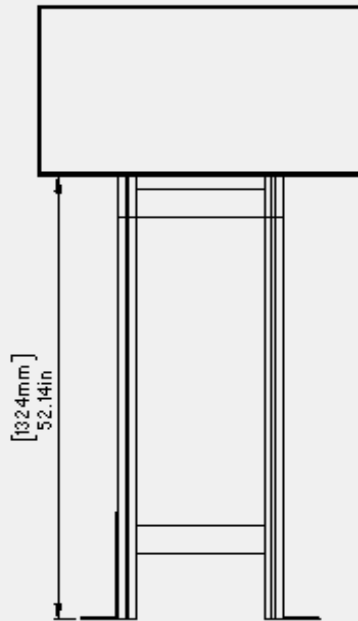

# Monitor Bracket Instructions

## Extrusion Channel Applications



### EXT-SM-MB

Vesa Pattern: 75 x 75  
up to 200 x 200mm

Max weight varies per application

**Assembled unit:**

10" w x 8.86" h x 2" d  
255mm (w) x 225mm (h) x 50mm (d)

**Shipping dimensions:**

14" l x 6" h x 4" d  
356mm (l) x 152mm (h) x 102mm (d)

**Approximate total shipping weight:**

6 lbs / 3 kg

**Recommended monitor sizes:**

23" - 42"

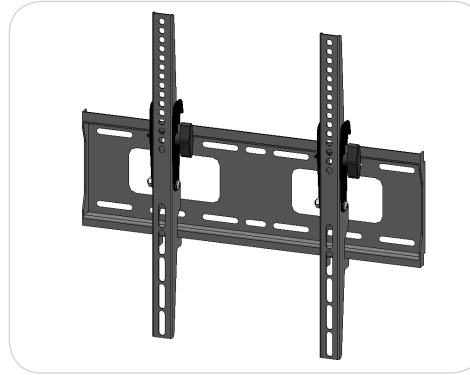

### EXT-M-MB

Vesa Pattern: 200 x 200  
up to 400 x 400mm

Max weight varies per application

**Assembled unit:**

17.6" w x 16.7" h x 1.6" d  
448mm (w) x 425mm (h) x 40mm (d)

**Shipping dimensions:**

24" l x 4" h x 4" d  
610mm (l) x 102mm (h) x 102mm (d)

**Approximate total shipping weight:**

8 lbs / 4 kg

**Recommended monitor sizes:**

32" - 55"

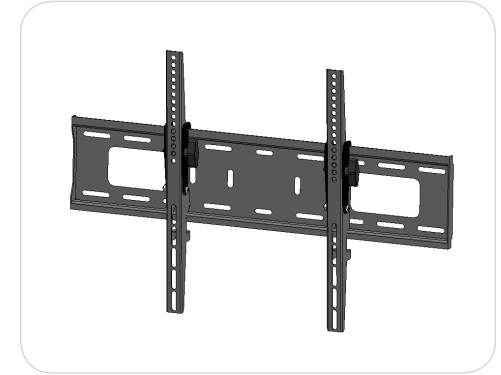

### EXT-LG-MB

Vesa Pattern: 200 x 200  
up to 600 x 400mm

Max weight varies per application

**Assembled unit:**

25.9" w x 16.7" h x 1.6" d  
658mm (w) x 425mm (h) x 40mm (d)

**Shipping dimensions:**

28" l x 6" h x 6" d  
711mm (l) x 152mm (h) x 152mm (d)

**Approximate total shipping weight:**

9 lbs / 5 kg

**Recommended monitor sizes:**

37" - 70"

## Included hardware:



LN-100

x2



M5 x 10

LN-LCD-SCW

x2



1/4"-20 x 1"

BOLT-1

x2

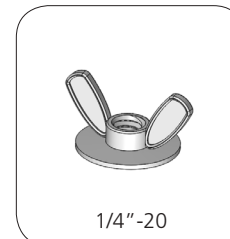

1/4"-20

Flange Wing nut

x2



# Extrusion Connection

## Channel Connection A



Locate all components needed to assemble the monitor mount with the channel connection A method. You will need (1) monitor bracket, (2) square head bolts, (2) washers, and (2) wing nuts.

**Step 1:** Insert the provided bolts through the washers and center top and bottom holes of the monitor mount. Loosely thread your wing nuts onto the end of the bolts.

**Step 2:** Slide the bolt heads down the extrusion channel.

**Step 3:** Tighten your wing nuts to lock the monitor bracket in place.

**Step 4:** Reference the included manufacturer monitor mount instructions for fastening your monitor to the bracket.

## Channel Connection B

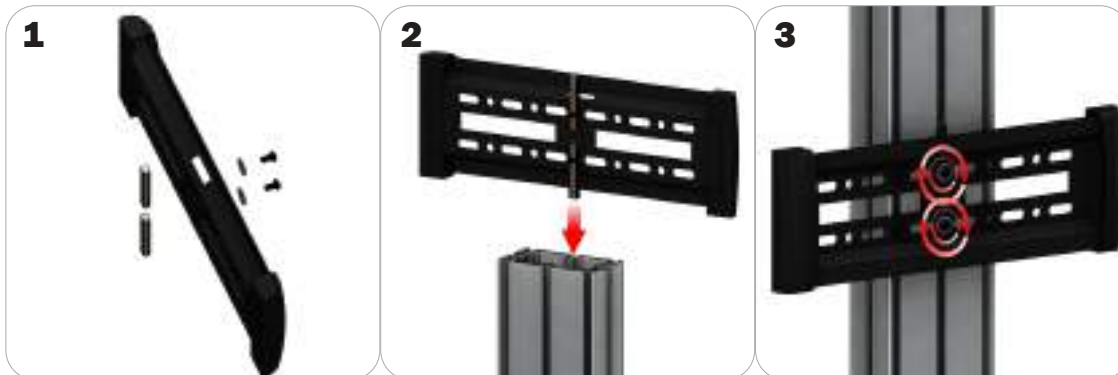

Locate all components needed to assemble the monitor mount with the channel connection B method. You will need (1) monitor bracket, (2) LN-LCD-SCW, (2) LN-100, and (2) washers.

**Step 1:** Loosely thread the LN-LCD-SCW screws through the washers, the center top and bottom holes of the monitor bracket, and through the LN-50 holes.

**Step 2:** Slide the LN-100s down the extrusion channel.

**Step 3:** Tighten your LN-LCD-SCW to lock the monitor bracket in place.

**Step 4:** Reference the included manufacturer monitor mount instructions for fastening your monitor to the bracket.

# Extrusion Connection

## TRI-30MM Channel Tube Connection



Locate all components needed to assemble the monitor mount with the TRI-30MM Channel Tube Connection method. You will need (1) monitor bracket, (2) Square Bolts, and (2) Wingnuts.

**Step 1:** Slip the head of the square bolts into the extrusion channel of the tube.

**Step 2:** Apply your monitor bracket to the protruding square bolts.

**Step 3:** Lock your monitor bracket to the square bolts using the provided wingnuts.

**Step 4:** Reference the included manufacturer monitor mount instructions for fastening your monitor to the bracket.