

# Hybrid Pro 20FT Modular Backwall Kit 31

HP-K-31

Hybrid Pro™ Modular Kit 31 is a dynamic modular exhibit that features an 8' tall backwall, six shelves for small product display with laminate soffit with puck lights and a central monitor mount that holds a large sized monitor. Push-fit SEG fabric graphics are easy to apply to the backwall and two Hybrid Pro Counters.



## features and benefits:

- Silver aluminum extrusion frames
- SEG push-fit fabric graphics
- Shelf color options: Silver, Black, Mahogany, Natural
- Monitor mount holds 37-70" LCD
- Monitor mount holds max weight: 50 lbs / 19 kg
- Ships freight in a roto-molded protective shipping case
- LCD monitor not included
- Lifetime hardware warranty against manufacturer defects

## dimensions:

Hardware

Assembled unit:  
236.47" w x 95.45" h x 33.58" d  
6007mm(w) x 2425mm(h) x 853mm(d)

Approximate weight:  
526 lbs / 239 kg

Shipping

Packing case(s):  
SCRATE

Shipping dimensions:  
57" l x 59" h x 34" d  
1448mm(l) x 1499mm(h) x 864mm(d)

Approximate total shipping weight:  
645 lbs / 293 kg



This product may include the following materials for recycle:  
aluminum, select wood, fabric, cardboard, paper, steel, and plastics.

Graphic

Refer to related graphic template for more information.

Visit:  
<https://www.theexhibitorshandbook.com/download-graphic-templates>

## additional information:

Graphic material:

Dye-sublimation SEG push-fit fabric

When included in a larger kit, a different packaging solution will be listed to accommodate all contents of the kit. Individual packaging no longer provided.

### Panel Colors:



### Tabletop Colors:

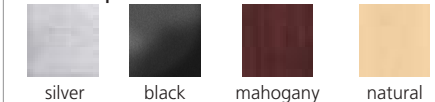

**3 person assembly recommended:**



We are continually improving and modifying our product range and reserve the right to vary the specifications without prior notice. All dimensions and weights quoted are approximate and we accept no responsibility for variance. E&OE. See Graphic Templates for graphic bleed specifications.

# Included In Your Kit

Tools, Components, & Connectors

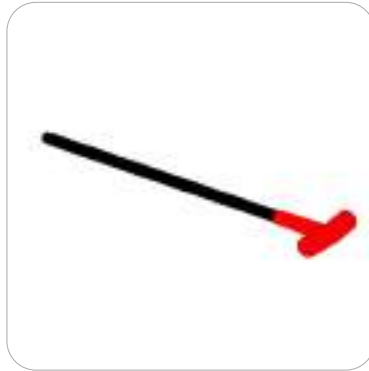

ALLEN KEY 5MM x1



CB9 x20



IB2 x13



HP-SOFFET-PUCK-1 x2



SW-FOOT-500-LN x2



PHFC2-750-MCB9-MCB9 x4



FC-50-SPACER x8



PHFC4-725-L1-MCB9 x8



PHFC2-1000-L1-MCB9-SIDE x4



PHFC2-1200-L-MCB9-SIDE x4

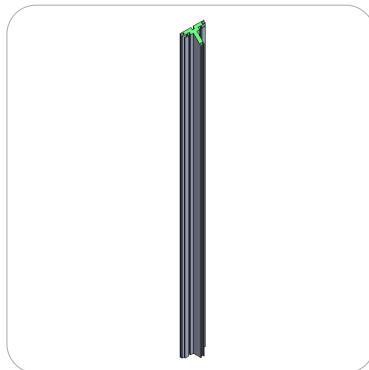

PHFC4-1200-L-MCB9 x12



PHFC2-750-L-MCB9 x4



PH1-1155-L-L1 x2

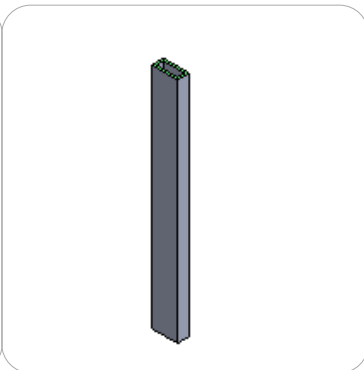

PH4-300-TG x2



PM2S2-1200-A165-N x4

# Included In Your Kit

Components



PM4S3-MK-SHELF-UNIT x2



PM4S3-MK-L x1



CBE-50 x8

GRAPHICS

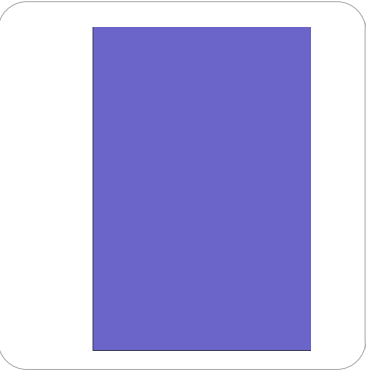

HP-31-A-G x1

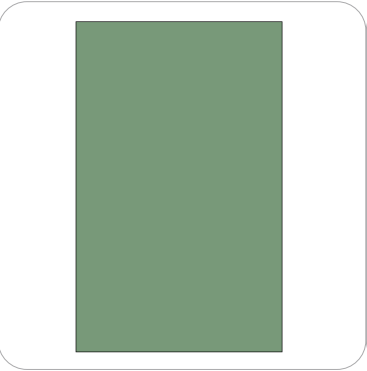

HP-31-J-G x1

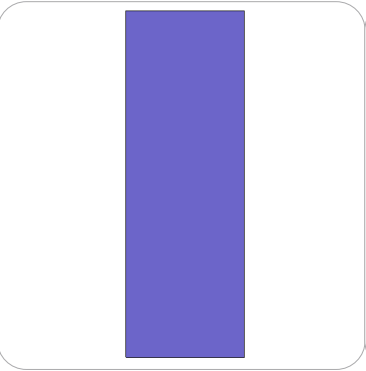

HP-31-B-G x1

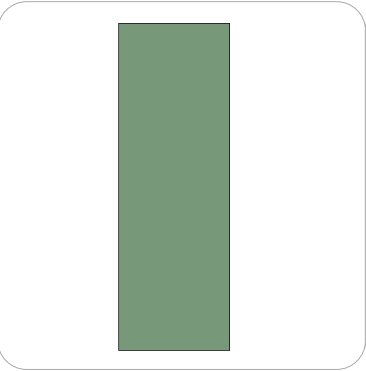

HP-31-G-G x1

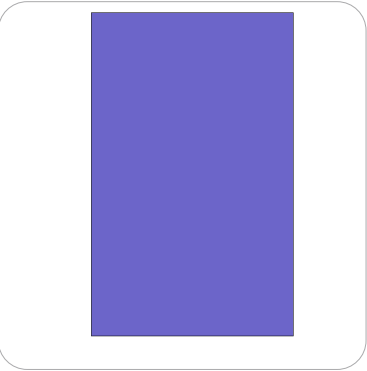

HP-31-C-G x1

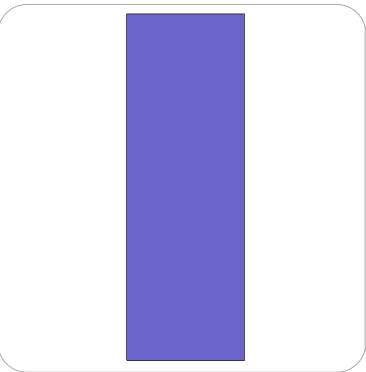

HP-31-D-G x1

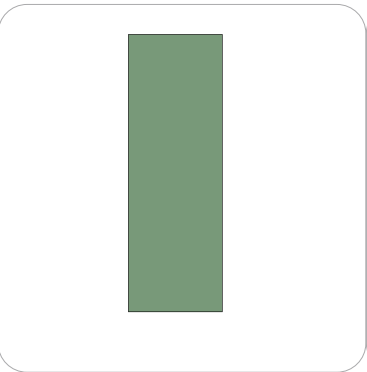

HP-31-I-G x1

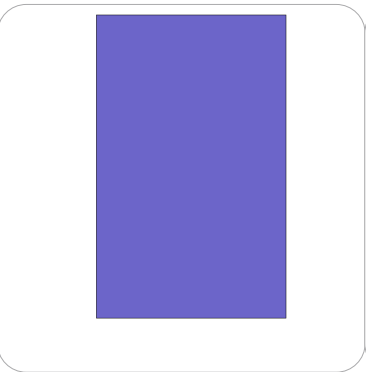

HP-31-E-G x1

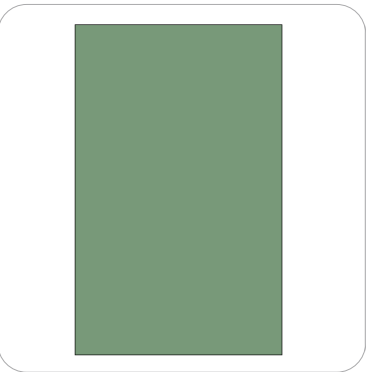

HP-31-H-G x1

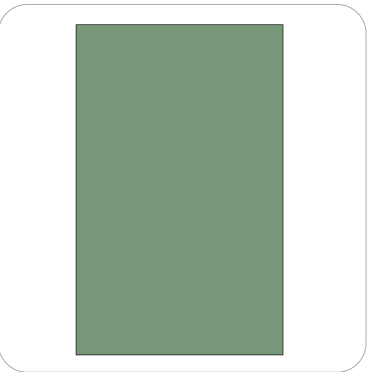

HP-31-F-G x1

# Layout Diagram

HP-K-31

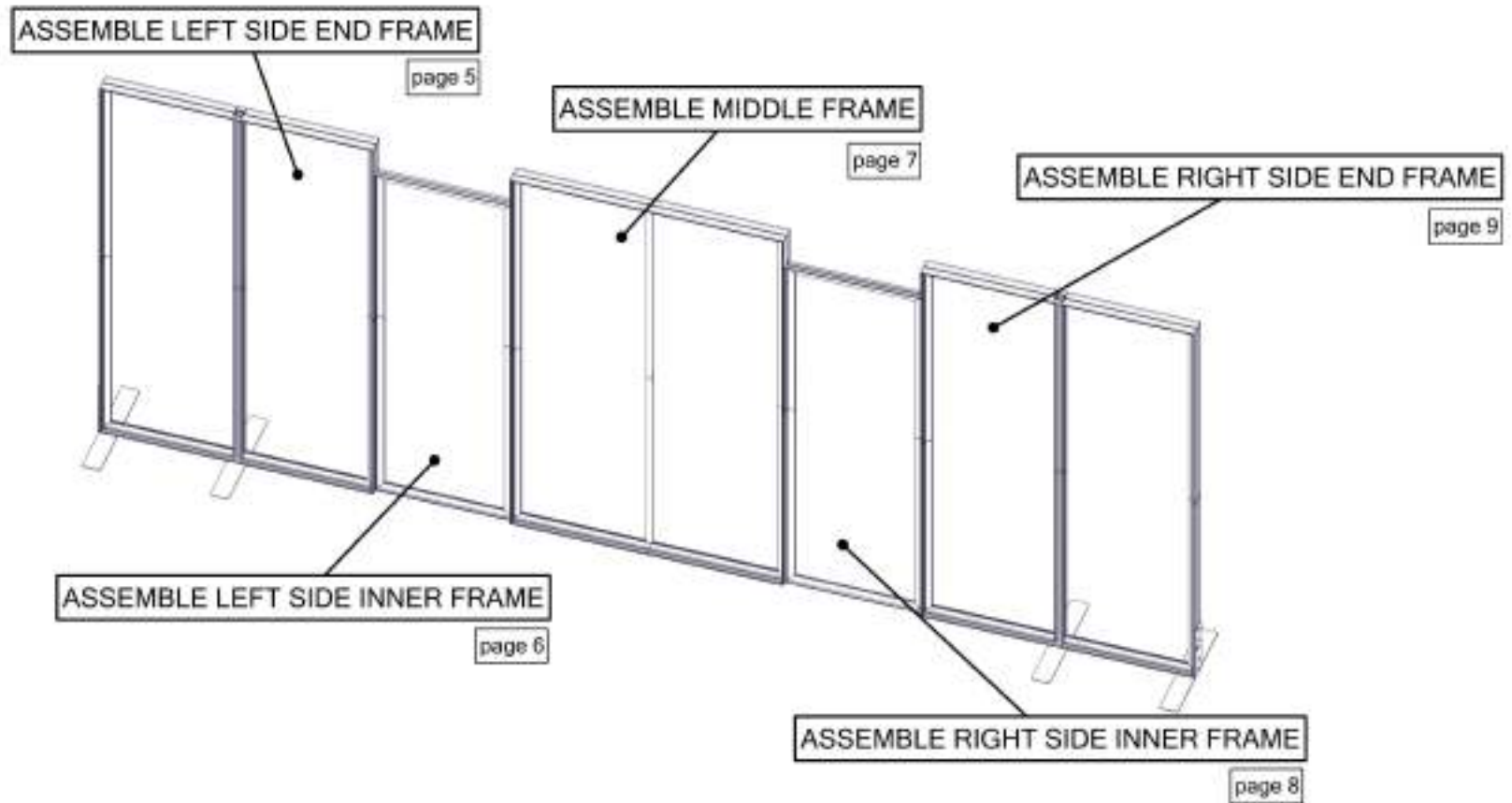

**- ASSEMBLE ASSEMBLE LAYOUT**

# Exploded Diagram

HP-K-31

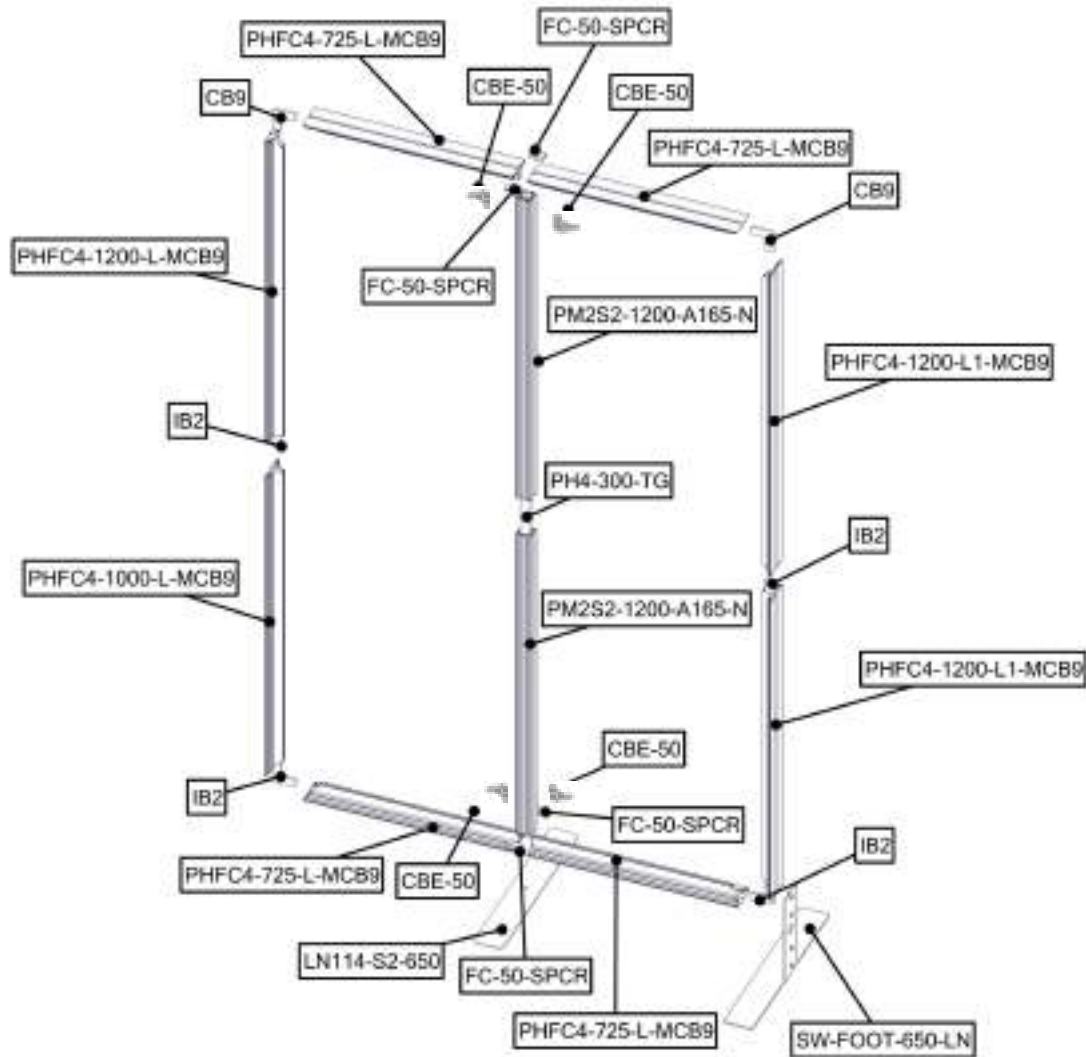

**- ASSEMBLE LEFT SIDE END FRAME**



# Exploded Diagram

HP-K-31

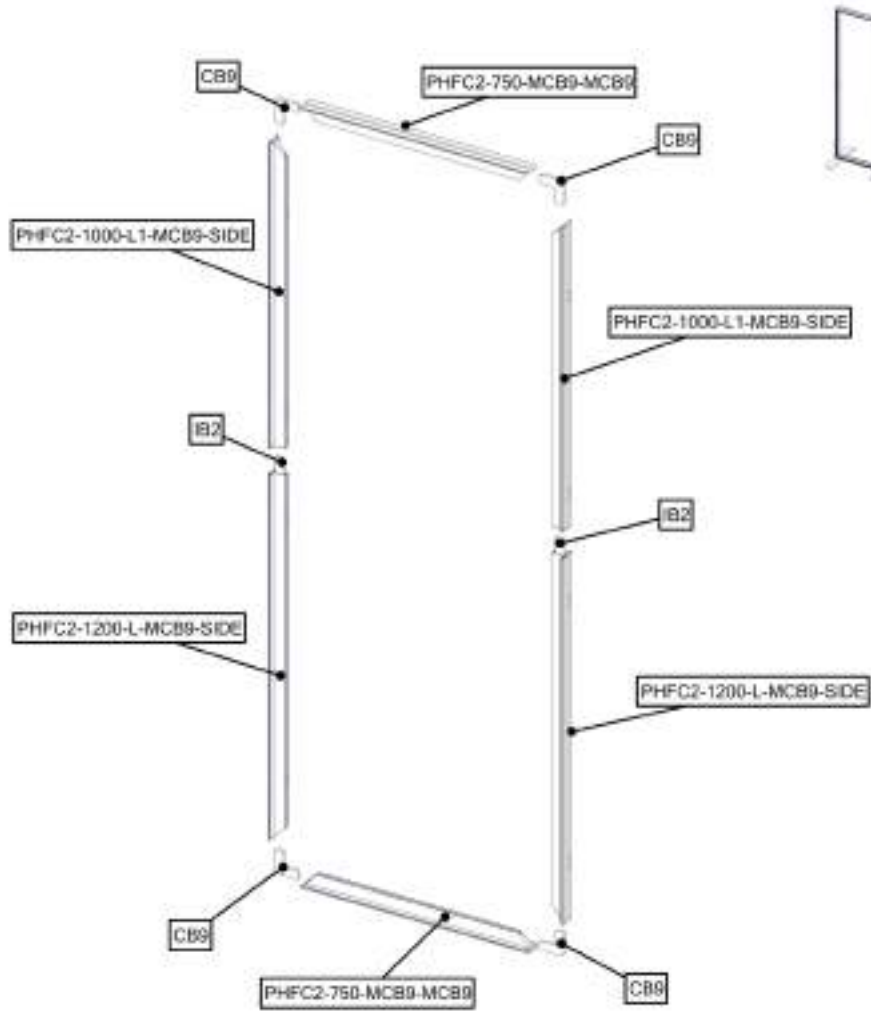

**- ASSEMBLE LEFT SIDE INNER FRAME**

# Exploded Diagram

HP-K-31

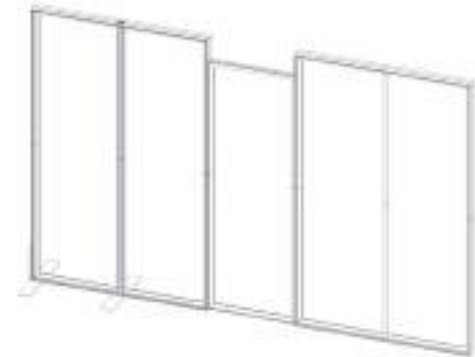
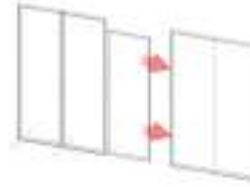
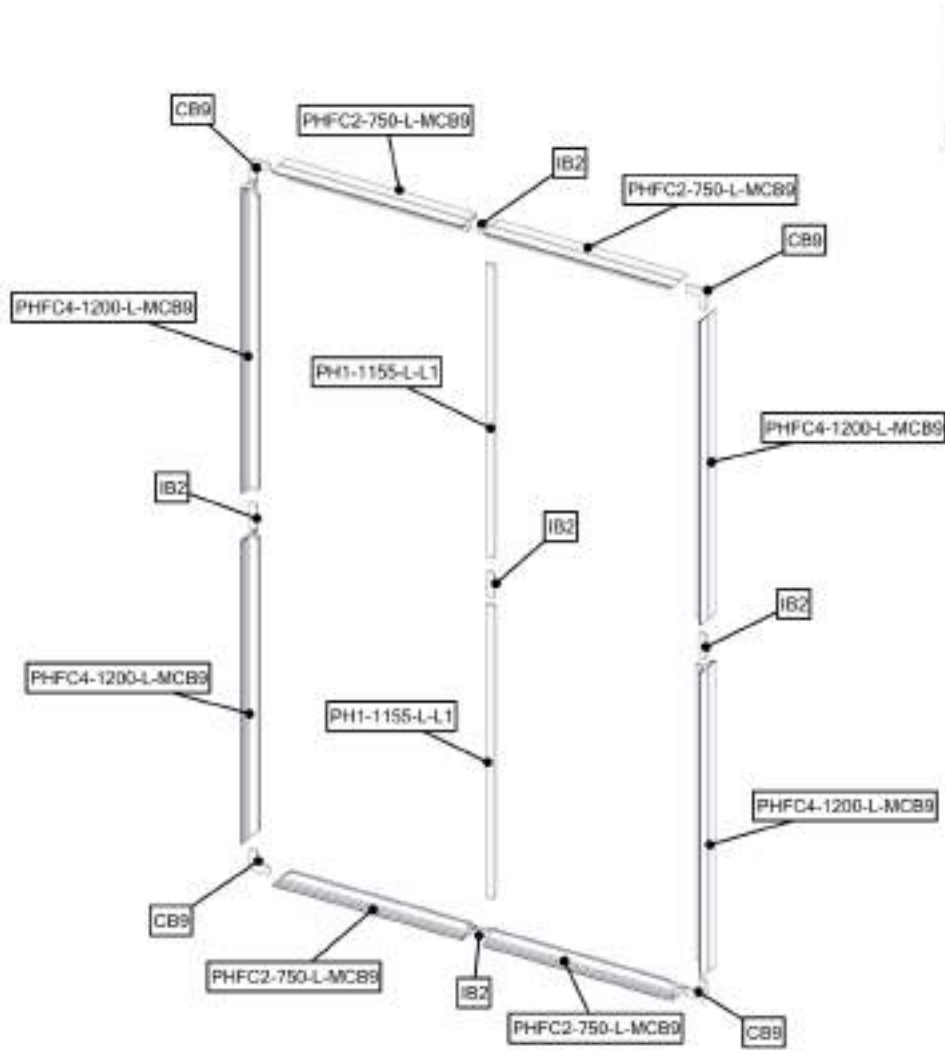

**- ASSEMBLE MIDDLE FRAME**

# Exploded Diagram

HP-K-31

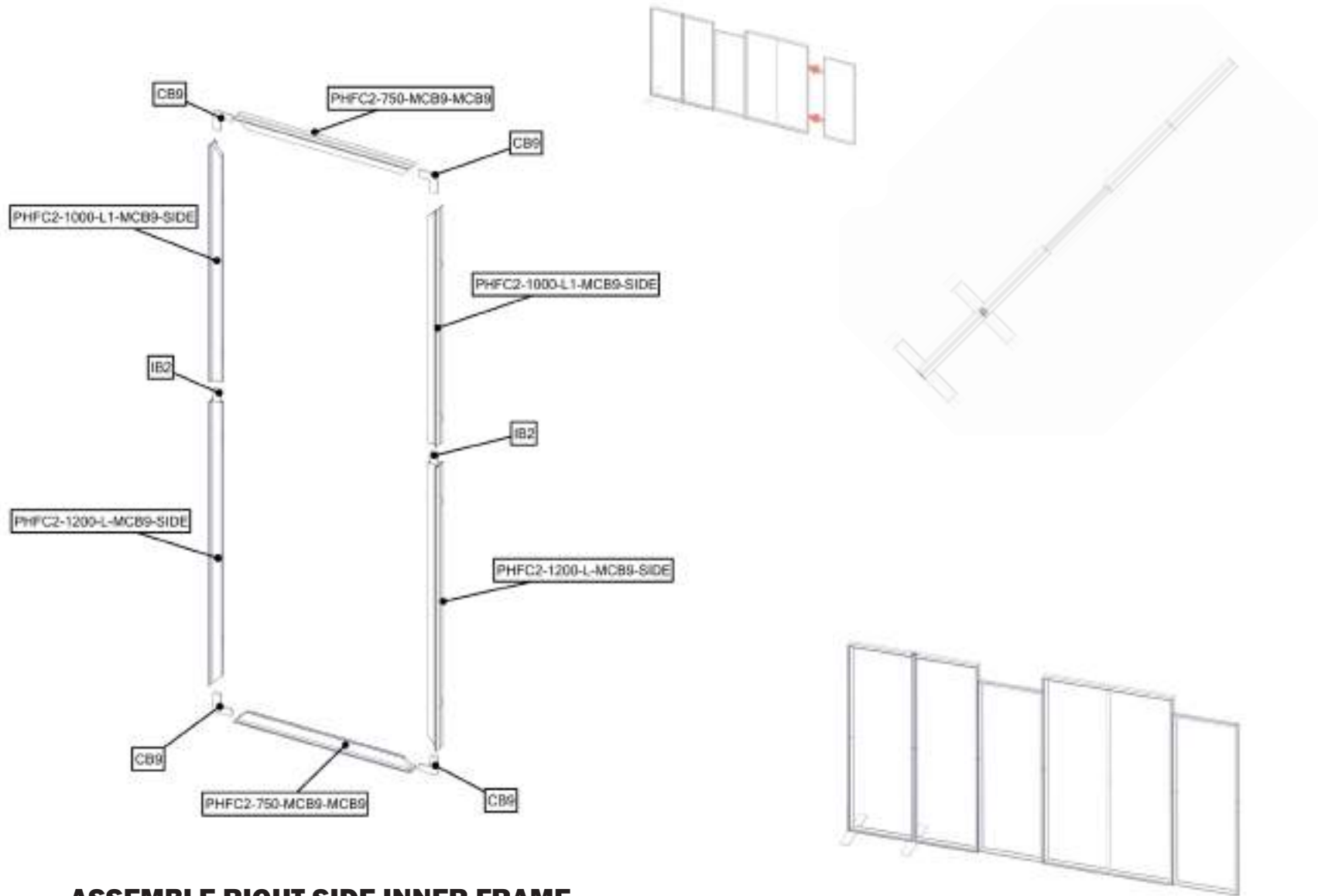

**- ASSEMBLE RIGHT SIDE INNER FRAME**





# Exploded Diagram

HP-K-31

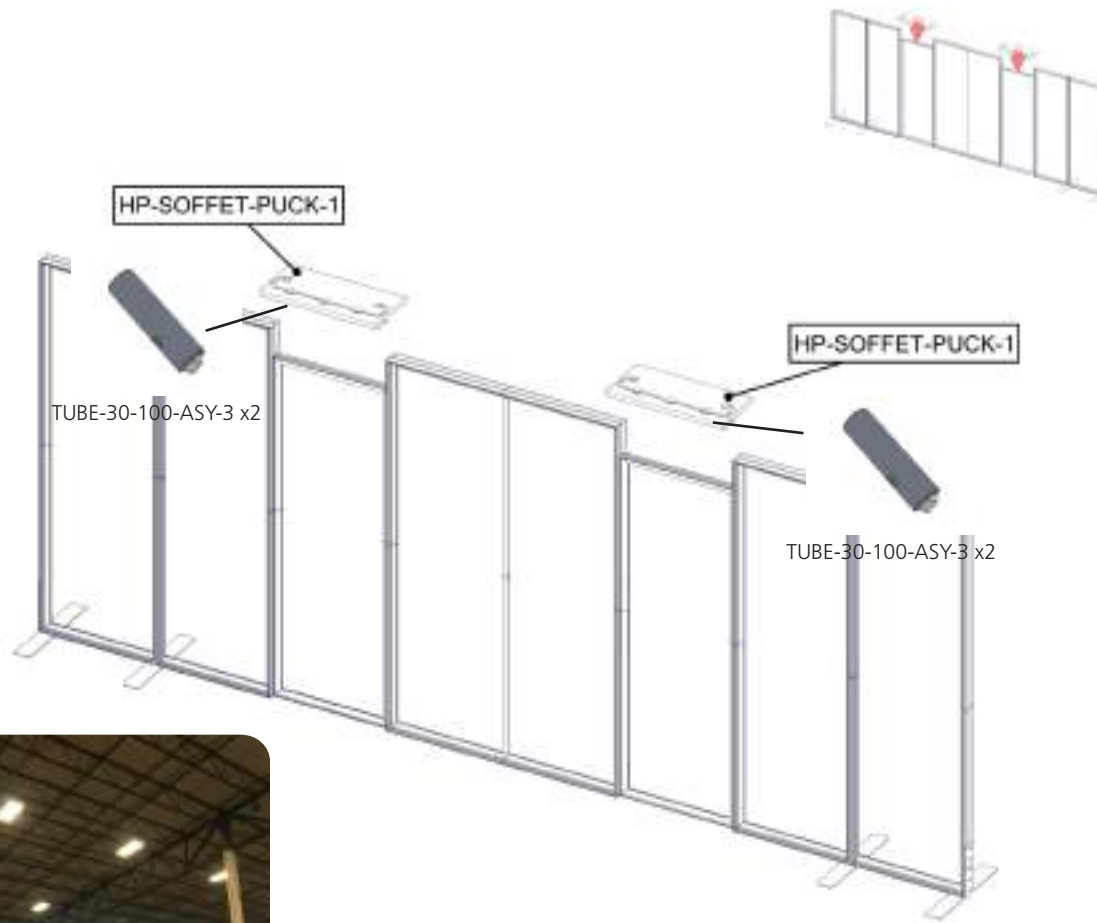

**- ATTACH SOFFET TO INNER FRAMES**

# Exploded Diagram

HP-K-31

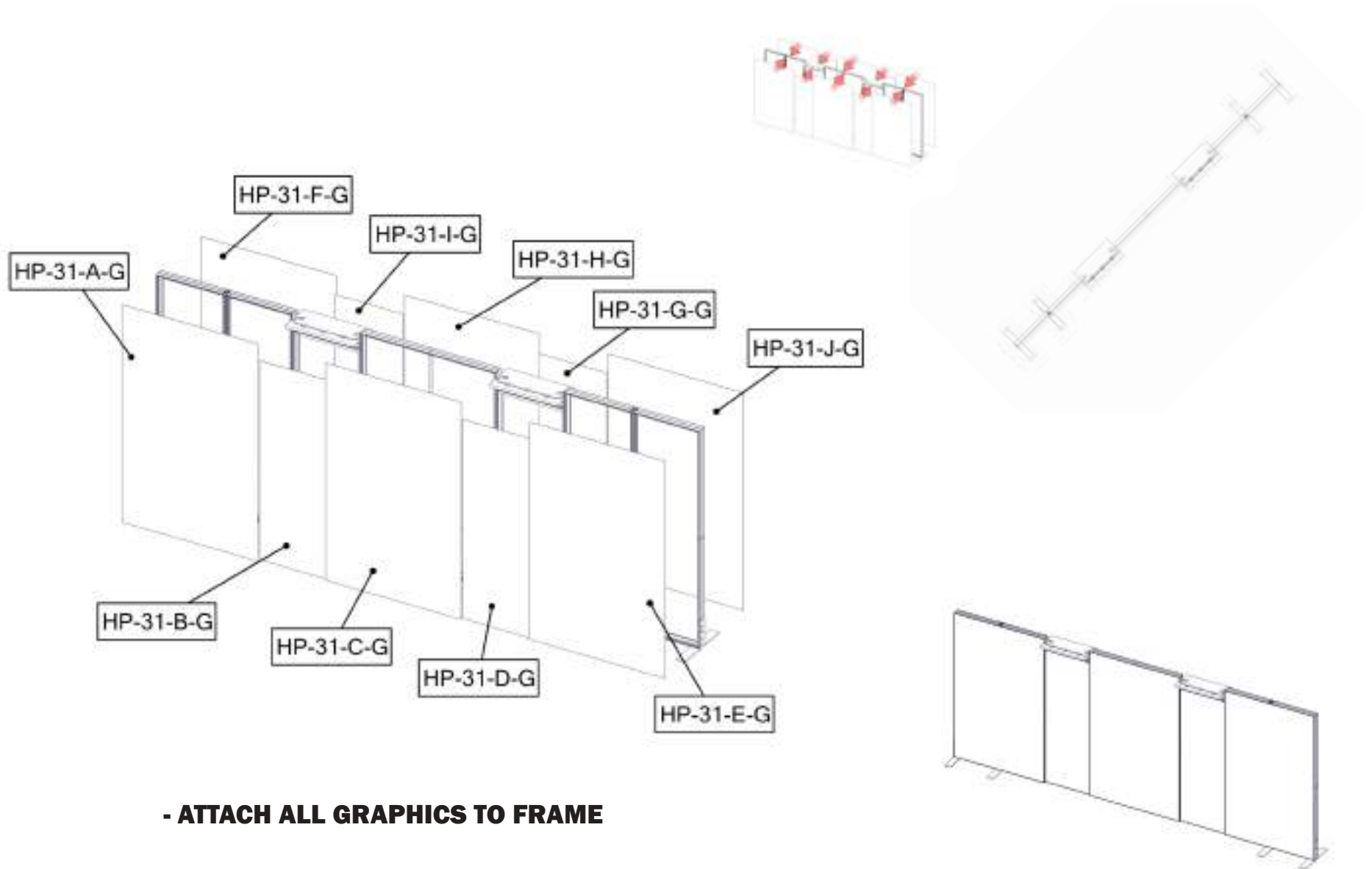

**- ATTACH ALL GRAPHICS TO FRAME**

# Exploded Diagram

HP-K-31



STEP 1

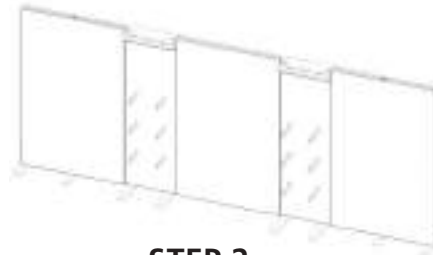

STEP 2

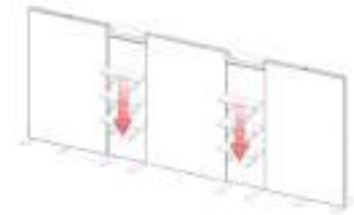

STEP 3

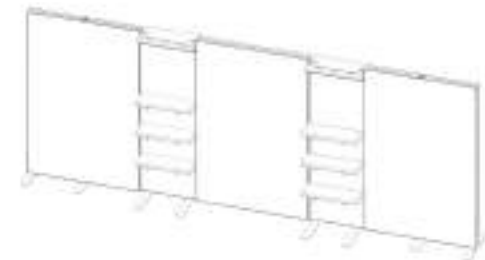
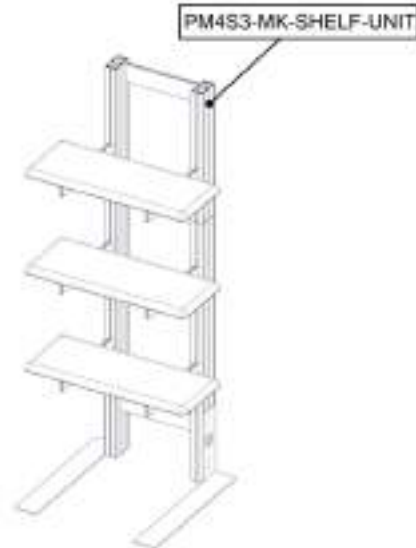
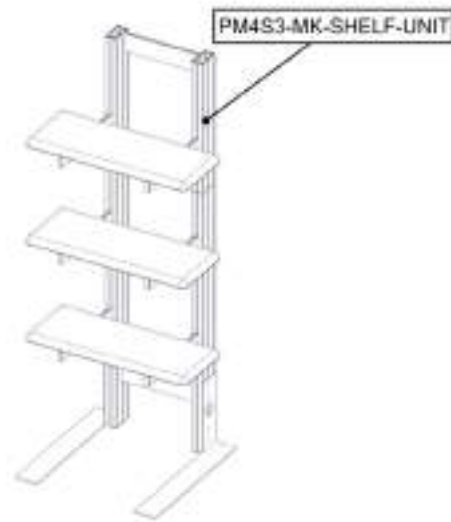

**BACK-WALL SETUP COMPLET**



**- ATTACH PLACEMENT OF PM4S3-MK-SHELF-UNIT**

**\*REFERENCE TO ATTACH PDF ON PM4S3-MK-SHELF-UNIT FOR QUESTIONS OR DETAILS ON ASSEMBLY**

# Exploded Diagram

HP-K-31



**STEP 1**



**STEP 2**



**- PLACEMENT OF PM4S3-MK-L**

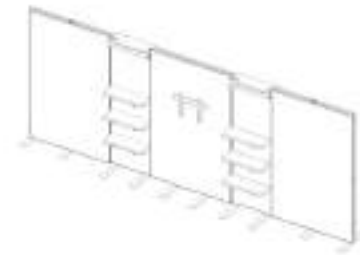

**\*REFERENCE TO ATTACH PDF ON PM4S3-MK-SHELF-UNIT FOR QUESTIONS OR DETAILS ON ASSEMBLY**

# Complete Diagram

HP-K-31

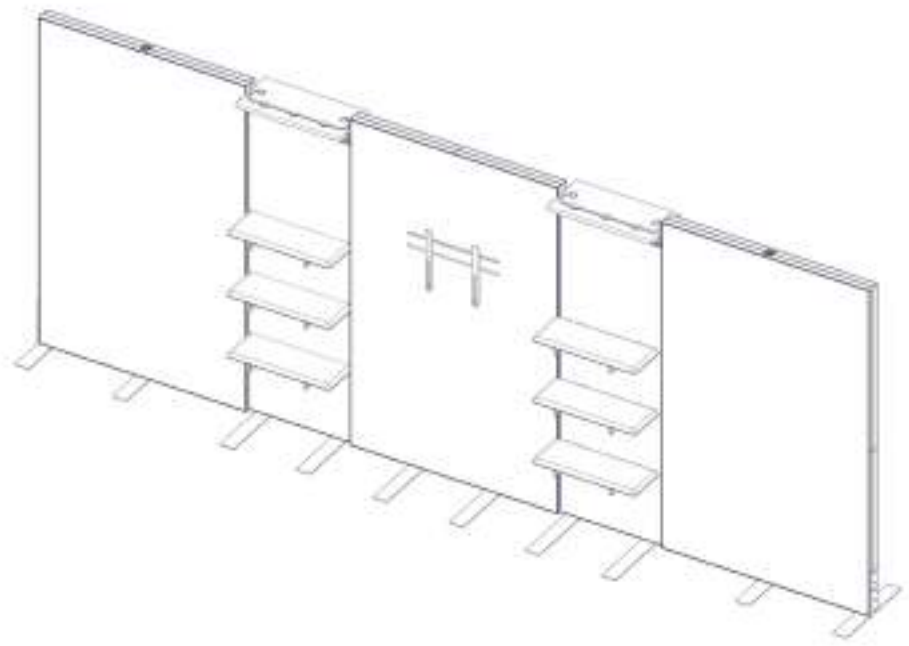

**SETUP COMPLETE**

# Suggested Kit Layout

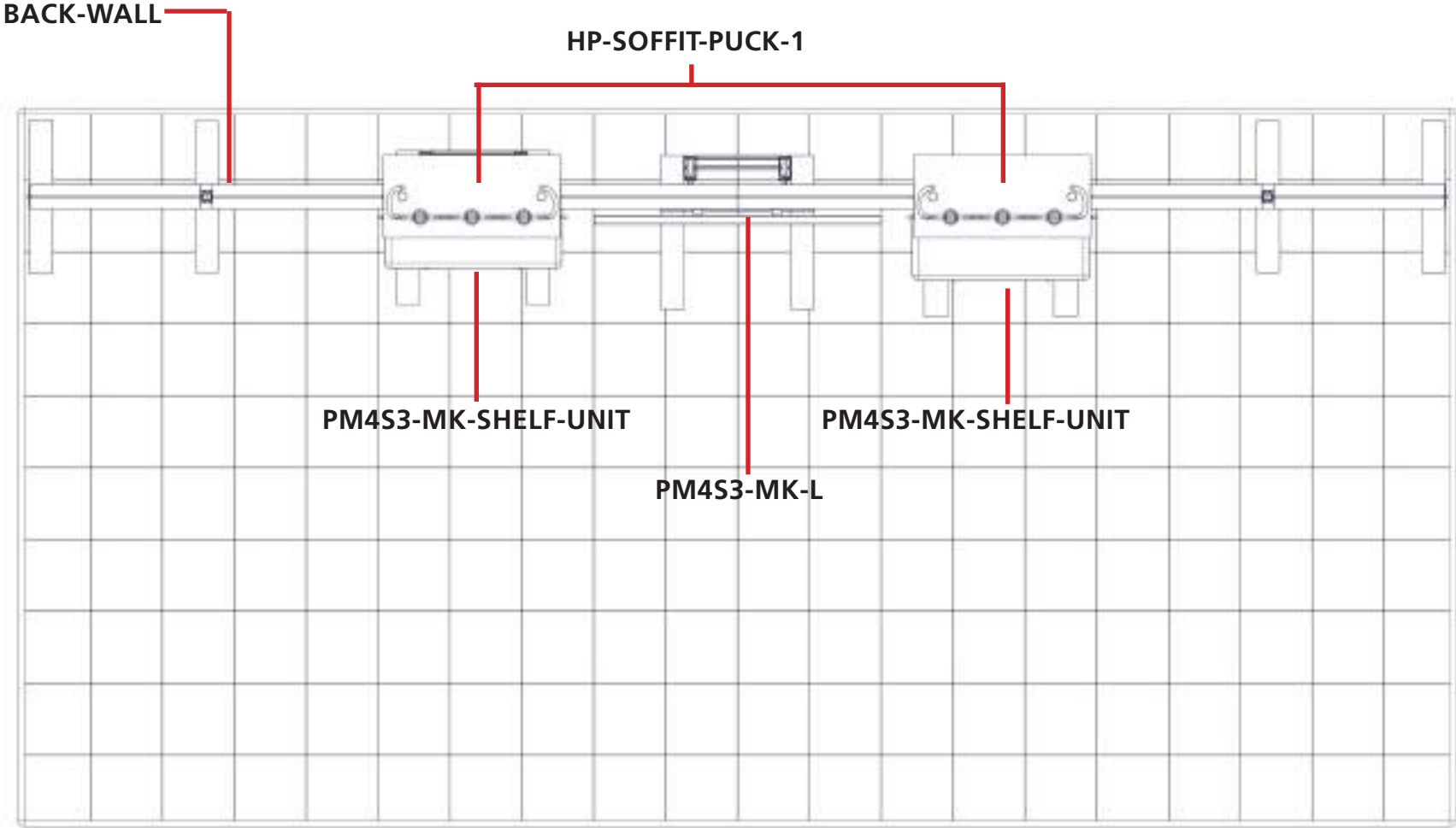

# Kit Assembly

## Step by Step

### Step 1.

Gather the components to build the left side end frame. Use the Exploded View and the Labeling Diagram for part labels.

Reference Connection Method(s) 2, 3, 5, 7, 8 AND 9 for more details.



### Step 2.

Gather the components to build the inner left side frame. Use the Exploded View and the Labeling Diagram for part labels.

Reference Connection Method(s) 1,4, and 11 for more details.



### Step 3.

Gather the components to build the middle frame. Use the Exploded View and the Labeling Diagram for part labels.

Reference Connection Method(s) 2, 3, 13, AND 14 for more details.

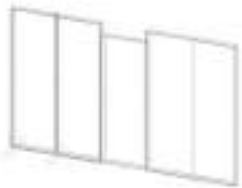

### Step 4.

Gather the components to build the inner right side frame. Use the Exploded View and the Labeling Diagram for part labels.

Reference Connection Method(s) 1, 4, and 11 for more details.

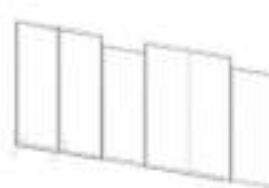



# Kit Assembly

## Step by Step

### Step 5.

Gather the components to build the right side end frame. Use the Exploded View and the Labeling Diagram for part labels.

Reference Connection Method(s) 2, 3, 5, 7, 8 AND 9 for more details.

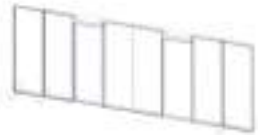

### Step 6.

Gather the components to attach soffets. Use the Exploded View and the Labeling Diagram for part labels.

Reference Connection Method(s) 10 for more details.

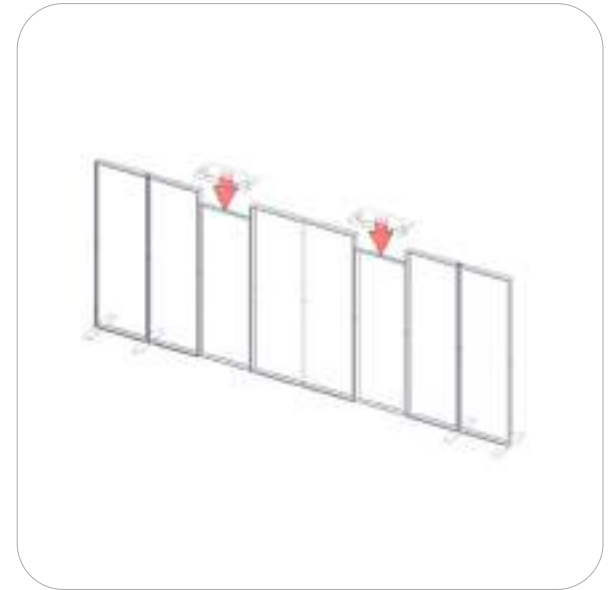
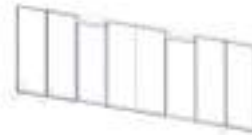

### Step 7.

Attach all graphics. Use the Exploded View and the Labeling Diagram for part labels.

Reference Connection Method(s) 12 for more details.

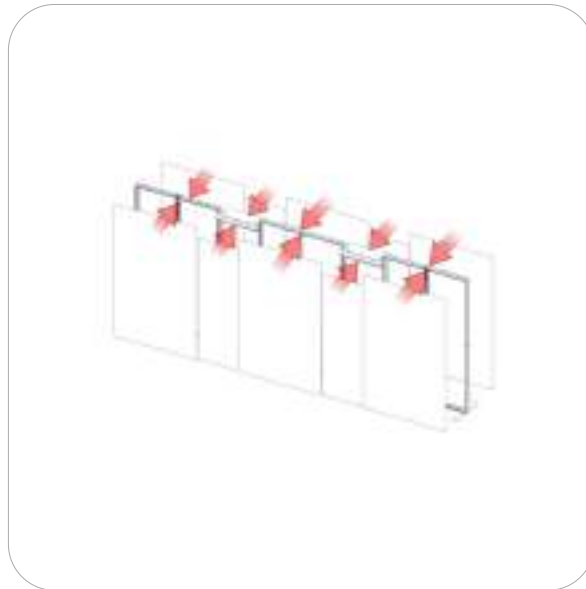
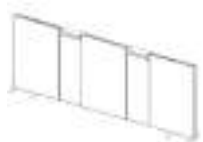

### Step 8.

Placement of PM4S3-MK-SHELF-UNIT. Use the Exploded View and the Labeling Diagram for part labels.

Reference Connection Method(s) PDF with detail assemble instructions follow this page

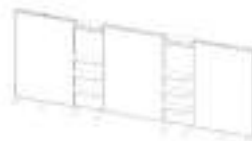

# Kit Assembly

## Step by Step

### Step 9.

Placment of PM4S3-MK-L.  
Use the Exploded View and the Labeling Diagram for part labels.

Reference Connection Method(s)  
PDF with detail assemble  
instructions follow this page



### Step 10.

complete setup

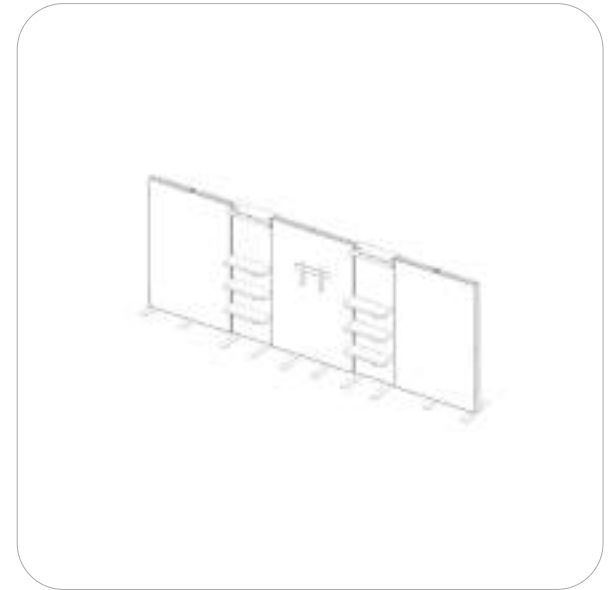

Setup is complete.

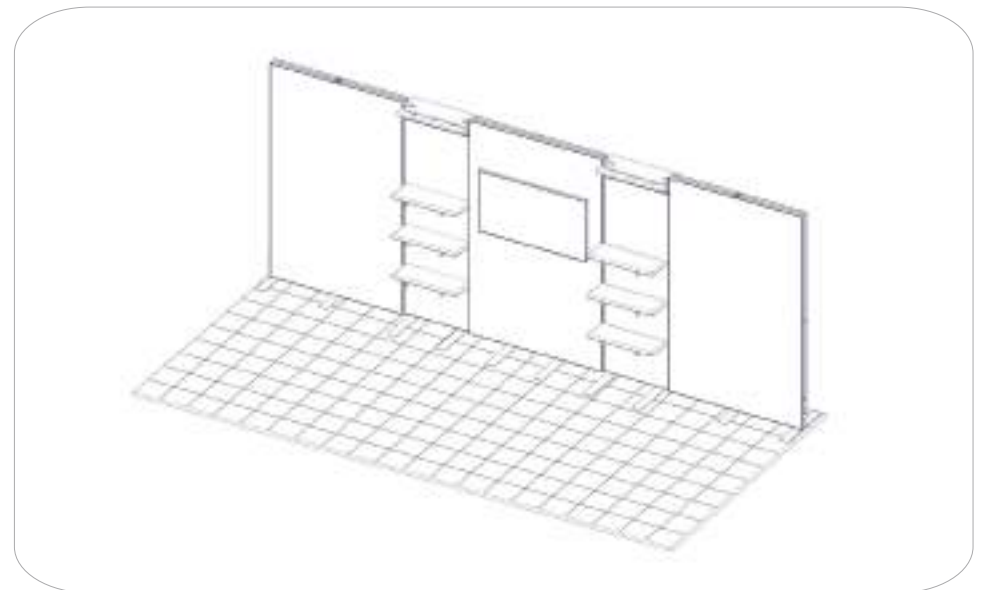

# Connection Methods

## Connection Method 1: CB9-PHFC2



First, insert the corner connector into the extrusion while holding in the lock button. Then, slide the next extrusion onto the same corner connector again holding in the lock button. Finally, use the provided allen key to lock the corner connector in place. Use the allen key tool to press the lock buttons, make quarter turns and do not over tighten the lock buttons.

## Connection Method 2: CB9-PHFC4



First, insert the corner connector into the extrusion while holding in the lock button with the allen key tool. Second, slide the next extrusion onto the same corner connector while holding in the lock button using the allen key tool. Third, use the allen key tool for locking the corner connector buttons in place. Use the allen key tool to make half turns clock-wise. Do not over tighten the lock buttons.

## Connection Method 3: IB2-PHFC4



First, insert the in-line connector into the extrusion while holding in the lock button with the allen key tool. Second, slide the next extrusion onto the same in-line connector while holding in the lock button using the allen key tool. Third, use the allen key tool for locking the in-line connector buttons in place. Use the allen key tool to make half turns clock-wise. Do not over tighten the lock buttons.

## Connection Method 4: IB2-PHFC2



First, insert the in-line connector into the extrusion while holding in the lock button. Then, slide the next extrusion onto the same in-line connector again holding in the lock button. Finally, use the provided allen key to lock the in-line connector in place. Use the allen key tool to turn the lock buttons, make quarter turns and do not over tighten the lock buttons.

# Connection Methods

## Connection Method 5: FC-50-SPCR

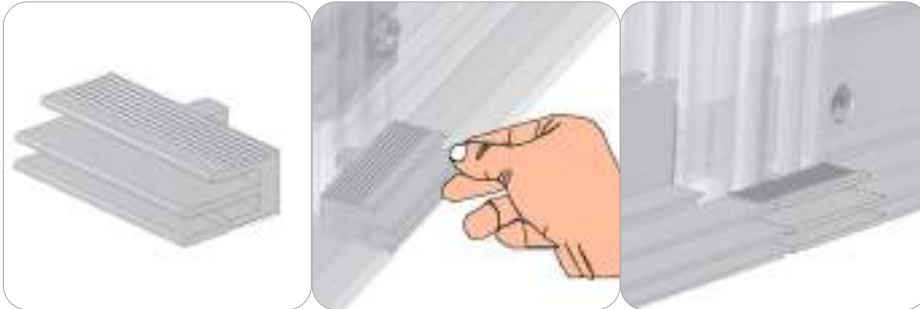

First, insert the spacer in the center channel of the PM2S2. This will cover the space of the void between both PHFC4 extrusions. Second, move to the desired position needed.

## Connection Method 6: PMFC4 to PMS2S



First, insert PHFC4 camlock into PMS2S side with one channel. Align the parts to your desired location. Use the tool pictured to lock the camlock in place. Be sure not to over-tighten, this could cause damage to parts or extrusions.

## Connection Method 7: PH4SC



First, slide the PH4SC-1 connector into the post until it rests on the PH2C stop. Second, then slide the top post onto the PH4SC-1 connector.

## Connection Method 8: SW-FOOT-650-LN



First, loosen the thumb screws and channel bars on the stabilizing bases. Do not disassemble them. Second, slide channel bars into the frame channel flush with the base of the frame. Finally, tighten the thumb screws and channel bars to secure the attachment.

# Connection Methods

## Connection Method 9: LN114-S2-650

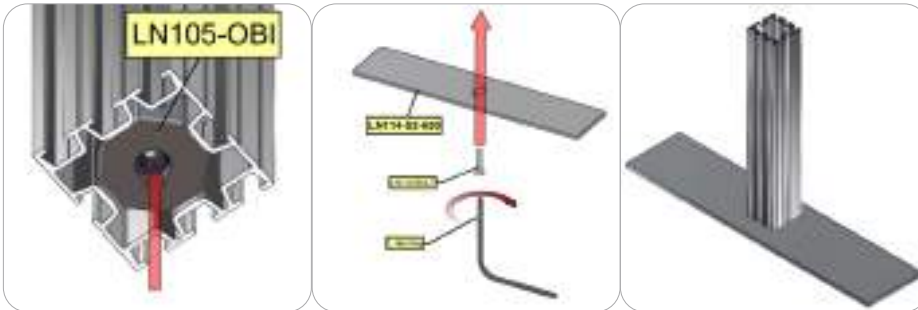

First, insert the spacer in the center channel of the PM2S2. This will cover the space of the void between both PHFC4 extrusions. Second, move to the desired position needed.

## Connection Method 10: TUB-30-100-ASY-3



Suffet comes as one assemble. First, connect the ADT-CAM-SM to the desired channel needed. Make sure the cam lock is loose to properly insert into channel. Second, tighten cam lock to a snug tight feel. Be sure not to over tighten. This could cause damage to the lock or extrusion.

## Connection Method 11: CAM-LOCK



First, place the cam lock teeth into the desired extrusion channel. Second, use the allen key tool to lock the cam buttons in place. Make half turns clock-wise to engage the cam-lock. Do not over tighten the lock buttons.

## Connection Method 12: SW-FOOT-300/500/650

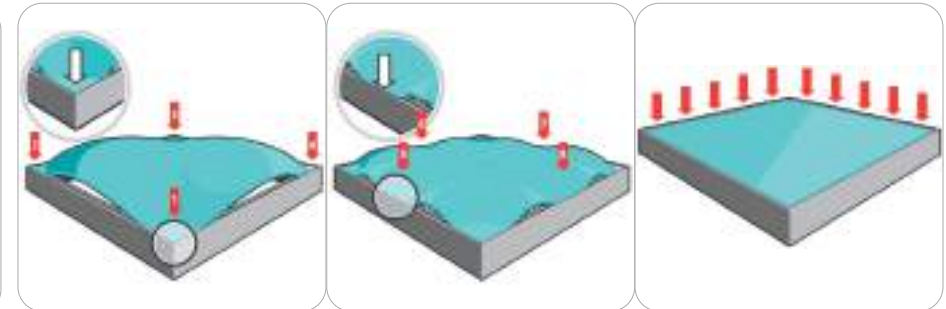

First, insert the silicone edge frame corners into the frame graphic channel (points 1 through 4). Second, insert the silicone edge frame sides into the frame graphic channel (points 5 through 8). Third, push the remaining silicone edge fabric into the frame graphic channel. Similar setup is recommended for the opaque liner. To remove these panels, simply pull the loop tag sewn near a corner.

# Connection Methods

Connection Method 13: PH1 to PHFC4

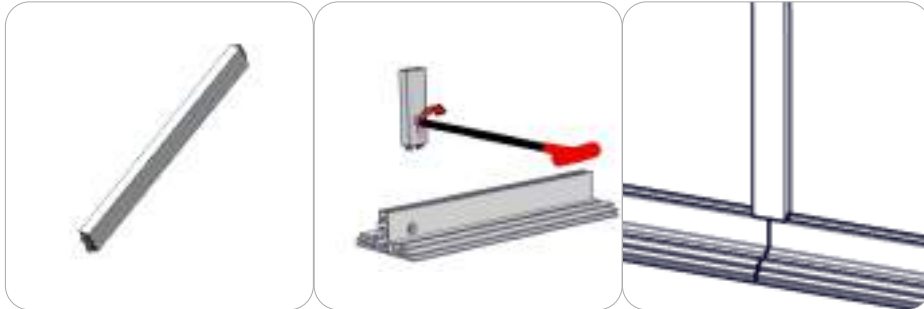

First, insert cam lock into desired channel of extrusion. Make sure cam lock is loose. Last, once in place, then tighten the screws to lock extrusions in place.

Connection Method 14: PH1 TO PH1

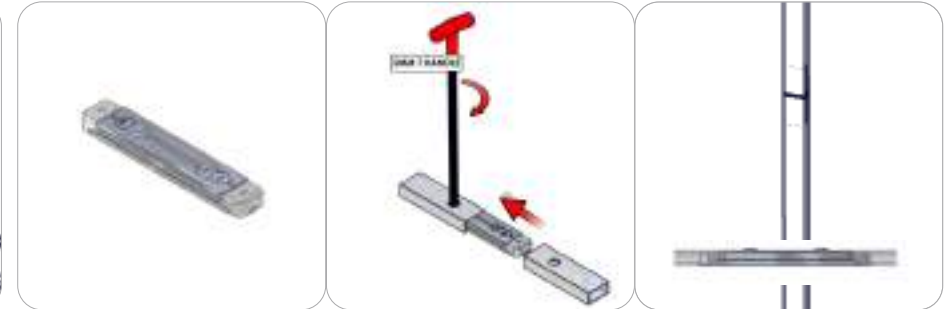

First, slide the eib2 into extrusion. Second, then tighten the screws to lock both extrusions together. Be sure not to over tighten this could cause damage to the extrusions or cam lock.

# Monitor Bracket Instructions

## Extrusion Channel Applications



### EXT-SM-MB

**Vesa Pattern: 75 x 75  
up to 200 x 200mm**

**Max weight varies per application**

**Assembled unit:**

10" w x 8.86" h x 2" d  
255mm (w) x 225mm (h) x 50mm (d)

**Shipping dimensions:**

14" l x 6" h x 4" d  
356mm (l) x 152mm (h) x 102mm (d)

**Approximate total shipping weight:**

6 lbs / 3 kg

**Recommended monitor sizes:**

23" - 42"

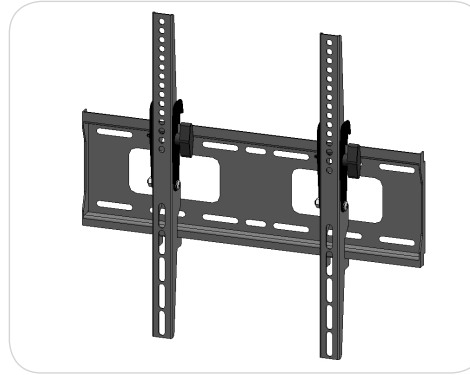

### EXT-M-MB

**Vesa Pattern: 200 x 200  
up to 400 x 400mm**

**Max weight varies per application**

**Assembled unit:**

17.6" w x 16.7" h x 1.6" d  
448mm (w) x 425mm (h) x 40mm (d)

**Shipping dimensions:**

24" l x 4" h x 4" d  
610mm (l) x 102mm (h) x 102mm (d)

**Approximate total shipping weight:**

8 lbs / 4 kg

**Recommended monitor sizes:**

32" - 55"

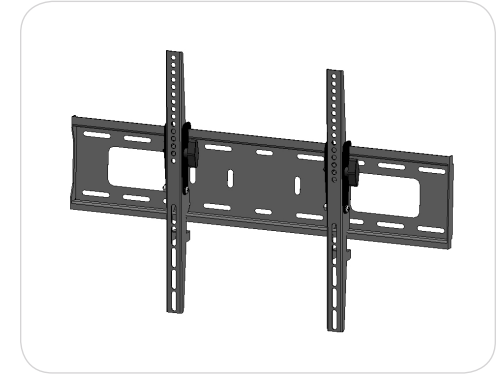

### EXT-LG-MB

**Vesa Pattern: 200 x 200  
up to 600 x 400mm**

**Max weight varies per application**

**Assembled unit:**

25.9" w x 16.7" h x 1.6" d  
658mm (w) x 425mm (h) x 40mm (d)

**Shipping dimensions:**

28" l x 6" h x 6" d  
711mm (l) x 152mm (h) x 152mm (d)

**Approximate total shipping weight:**

9 lbs / 5 kg

**Recommended monitor sizes:**

37" - 70"

## Included hardware:



**LN-100**

**x2**



**M5 x 10**

**LN-LCD-SCW**

**x2**



**1/4"-20 x 1"**

**BOLT-1**

**x2**

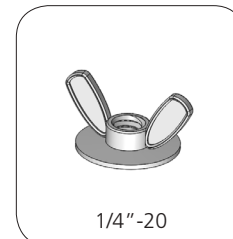

**1/4"-20**

**Flange Wing nut**

**x2**

# Extrusion Connection

## Channel Connection A

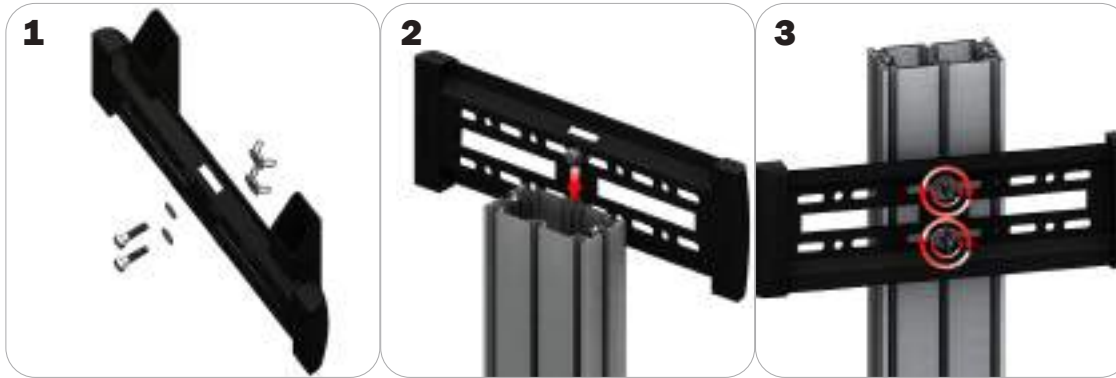

Locate all components needed to assemble the monitor mount with the channel connection A method. You will need (1) monitor bracket, (2) square head bolts, (2) washers, and (2) wing nuts.

**Step 1:** Insert the provided bolts through the washers and center top and bottom holes of the monitor mount. Loosely thread your wing nuts onto the end of the bolts.

**Step 2:** Slide the bolt heads down the extrusion channel.

**Step 3:** Tighten your wing nuts to lock the monitor bracket in place.

**Step 4:** Reference the included manufacturer monitor mount instructions for fastening your monitor to the bracket.

## Channel Connection B

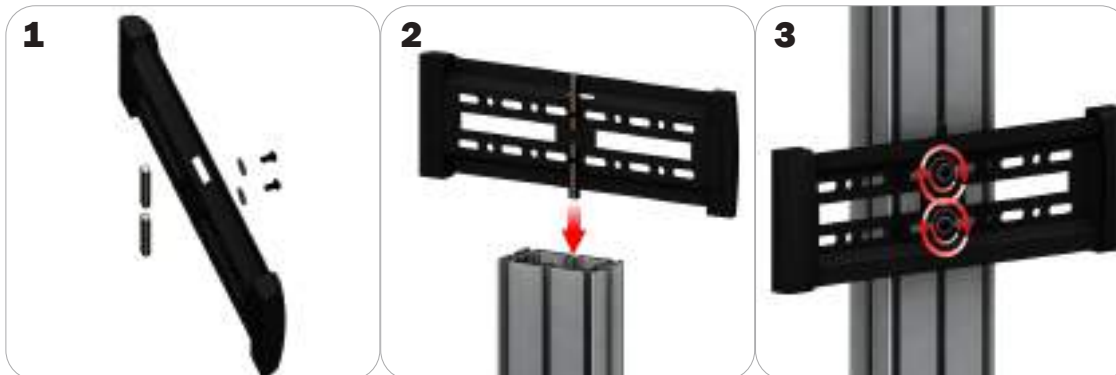

Locate all components needed to assemble the monitor mount with the channel connection B method. You will need (1) monitor bracket, (2) LN-LCD-SCW, (2) LN-100, and (2) washers.

**Step 1:** Loosely thread the LN-LCD-SCW screws through the washers, the center top and bottom holes of the monitor bracket, and through the LN-50 holes.

**Step 2:** Slide the LN-100s down the extrusion channel.

**Step 3:** Tighten your LN-LCD-SCW to lock the monitor bracket in place.

**Step 4:** Reference the included manufacturer monitor mount instructions for fastening your monitor to the bracket.



# Extrusion Connection

## TRI-30MM Channel Tube Connection



Locate all components needed to assemble the monitor mount with the TRI-30MM Channel Tube Connection method. You will need (1) monitor bracket, (2) Square Bolts, and (2) Wingnuts.

**Step 1:** Slip the head of the square bolts into the extrusion channel of the tube.

**Step 2:** Apply your monitor bracket to the protruding square bolts.

**Step 3:** Lock your monitor bracket to the square bolts using the provided wingnuts.

**Step 4:** Reference the included manufacturer monitor mount instructions for fastening your monitor to the bracket.

# Freestanding Monitor Kiosk

PM4S3-MK-M  
PM4S3-MK-L

PM4S3-MK-M-MSHELF  
PM4S3-MK-L-MSHELF

PM4S3-MK-SHELF-UNIT

The Freestanding Monitor Kiosk is a superior multimedia display that can be used for multiple applications, as well as in trade show exhibits and for events. Kiosks include monitor mounts to support a medium or large size TV, and a corresponding medium or large shelf may be added. Monitor mounts support TV's up to 40 lbs and 32" - 70" in size, and can be adjusted to the perfect height; an included shelf can hold up to 15 lbs. The Shelf Unit is a great addition that proudly displays small products. Install the Freestanding line behind a fabric backwall for a truly impressive display.

Freestanding Monitor Kiosk



PM4S3-MK-M  
PM4S3-MK-L

Freestanding Monitor Kiosk with Shelf



PM4S3-MK-M-MSHELF  
PM4S3-MK-L-MSHELF

Freestanding Shelf Unit



PM4S3-MK-SHELF-UNIT

## features and benefits:

- Premium aluminum extrusion frames with cam lock and tension glide assembly
- Easy to store and ship
- Quick to set up
- Weighted feet for added stability
- Kits may include: a medium or large monitor mount, shelf, or combination
- Choice of medium or large monitor mount options. (Freestanding Monitor Kiosk with Shelf or Freestanding Shelf)
- Lifetime limited hardware warranty against manufacturer defects

## dimensions:

### Hardware

Assembled unit (no shelf):  
25.59" w x 70.98" h x 25.59" d  
650mm(w) x 1803mm(h) x 650mm(d)

Assembled unit (with shelf):  
29.53" w x 70.98" h x 25.59" d  
751mm(w) x 1803mm(h) x 650mm(d)

Approximate weight:  
(excludes cases & monitor mount)

40 lbs / 19 kg

Add 10 lbs / 5 kg for each shelf

### Shipping

Packing case(s):  
1 OCE Case

Shipping dimensions:  
OCE: Expandable case length (l) may vary  
40" - 66" l x 18" h x 18" d  
1016mm-1677mm(l) x 458mm(h) x 458mm(d)

Approximate total shipping weight:  
Monitor Kiosk:  
(Case & monitor mount)  
Medium  
83 lbs / 38 kg  
Large  
85 lbs / 39 kg

## additional information:

-Medium monitor mount can hold 37-70" monitor/ max weight 40 lbs

-Large monitor mount can hold 40"-65" monitor/ max weight 40 lbs

-Monitor not included

-Shelf can hold suggested max weight: 15 lbs

-If shipping with backwall kit cases may vary

Monitor Kiosk with Shelf:  
(Case, monitor mount, & shelf)

Medium  
93 lbs / 43 kg  
Large  
95 lbs / 44 kg

Shelf Unit:  
(Case & shelves)  
116 lbs / 53 kg

We are continually improving and modifying our product range and reserve the right to vary the specifications without prior notice. All dimensions and weights quoted are approximate and we accept no responsibility for variance. E&OE. See Graphic Templates for graphic bleed specifications.

# Included In Your Freestanding Monitor Kiosk

Tools, Components, Connectors & Extrusions



5MM ALLEN-T x1

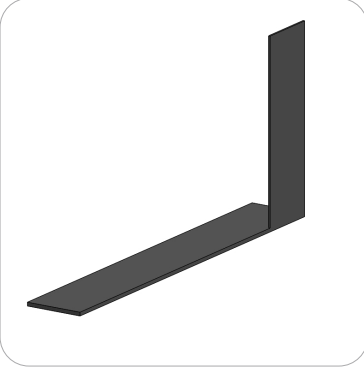

PM4S3-MM-FOOT-L x1



PM4S3-MM-FOOT-R x1



LN100 x6

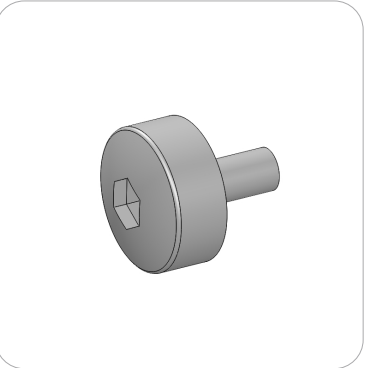

M5 THUMBSCREW x8



PH2-350-L-L x3



PH5-100-L-L x2



PM4S4-150 x2



PM4S3-600-A165-A165 x2



PM4S3-1200-A165-A165 x2



PH2-300-TG x2



EXT-M-MB (or) EXT-LG-MB x1  
Fastening Hardware Included



CBE-50 x2



# Included In Your Freestanding Monitor Kiosk with Shelf

Tools, Components, Connectors & Extrusions



5MM ALLEN-T x1



PM4S3-MM-FOOT-L x1



PM4S3-MM-FOOT-R x1



LN100 x6

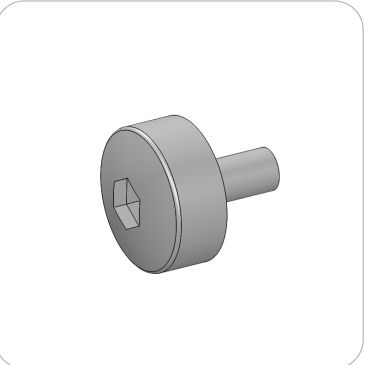

M5 THUMBSCREW x8



PH2-350-L-L x3



PH5-100-L-L x2



PM4S4-150 x2



PM4S3-600-A165-A165 x2



PM4S3-1200-A165-A165 x2



PH2-300-TG x2



EXT-M-MB (or) EXT-LG-MB x1  
Fastening Hardware Included



CBE-50 x4



# Included In Your Freestanding Monitor Kiosk with Shelf

Components, Connectors & Extrusions



PH-400-L-SIDE-MK x2

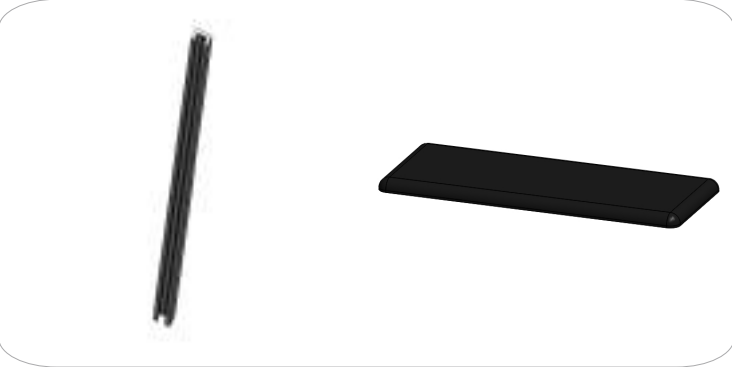

PE-1200 x2  
\*will ship preattached to shelf



CT21-MK-SHELF x1



LN605-EN x2



# Included In Your Freestanding Shelf

Tools, Components, Connectors & Extrusions



5MM ALLEN-T x1

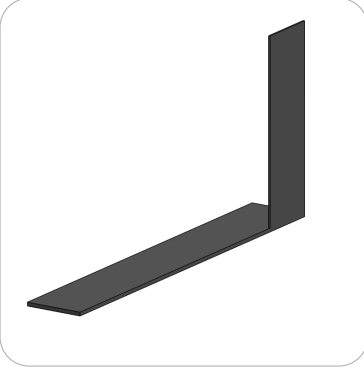

PM4S3-MM-FOOT-L x1



PM4S3-MM-FOOT-R x1



LN100 x6

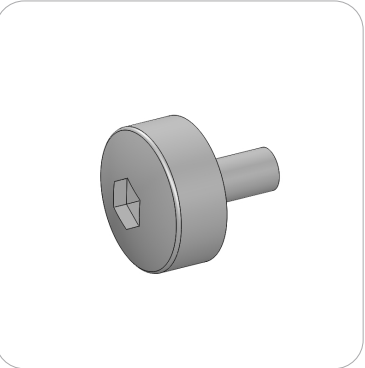

M5 THUMBSCREW x8



PH2-350-L-L x3



PM4S3-600-A165-A165 x2



PM4S3-1200-A165-A165 x2



PH2-300-TG x2



PH-400-L-SIDE-MK x6



PE-1200 x6  
\*will ship preattached to shelf



CT21-MK-SHELF x3



LN605-EN x6



# Exploded View

## PM4S3-MK-M PM4S3-MK-L

Please note:  
This is the kiosk frame build for  
either medium or large kit.

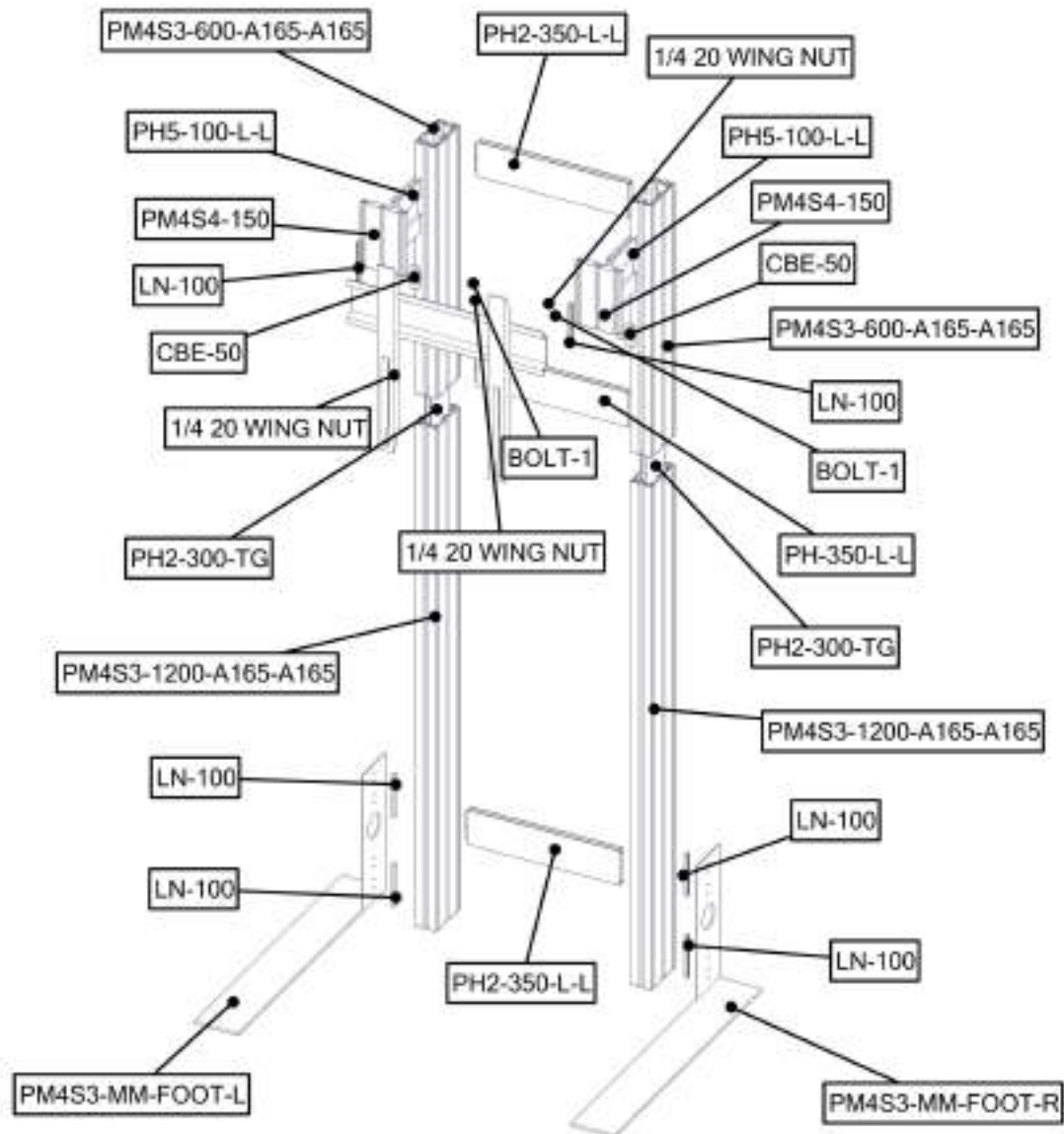

# Exploded View

## PM4S3-MK-M-MSHELF PM4S3-MK-L-MSHELF

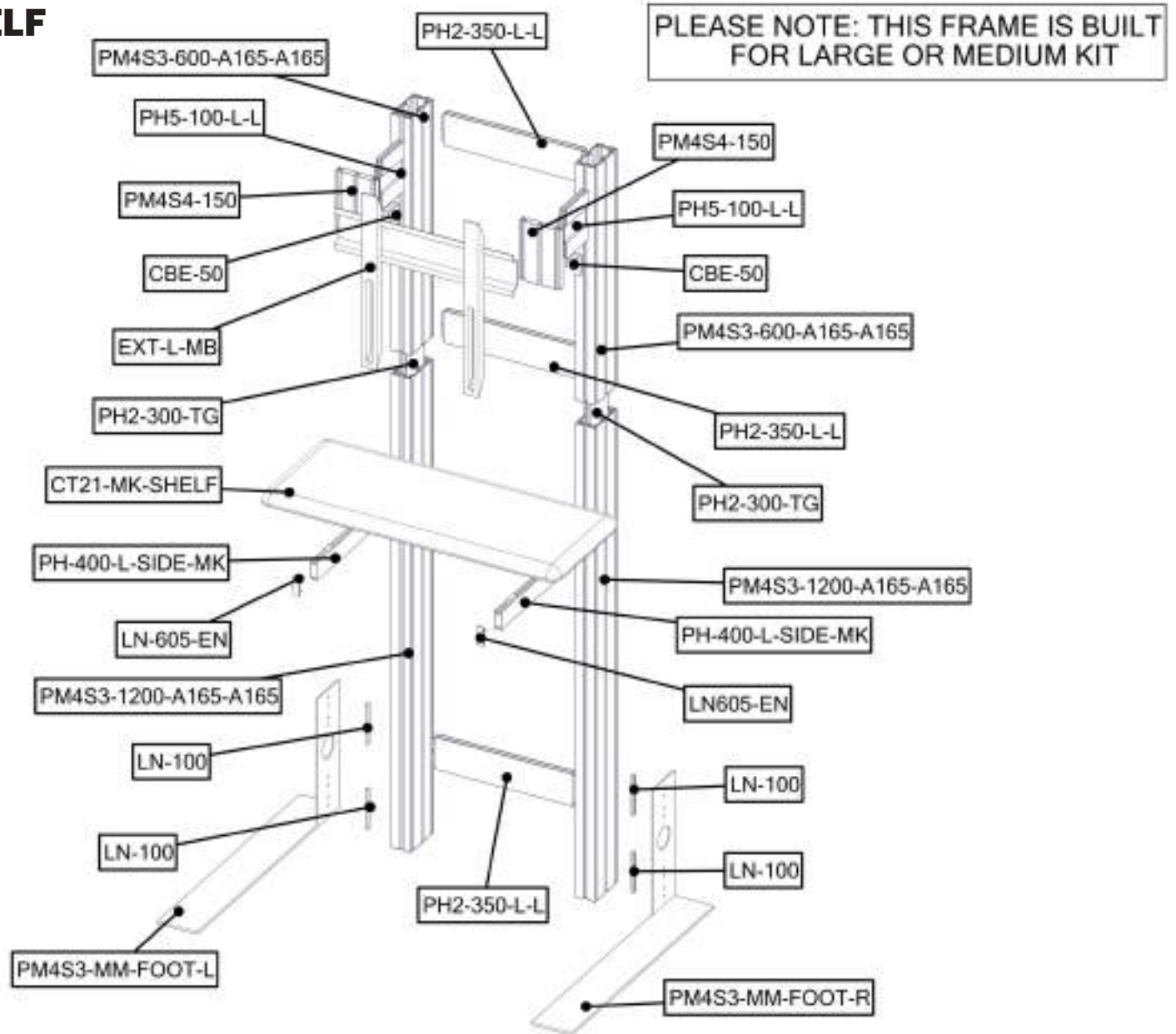



# Exploded View

## PM4S3-MK-SHELF-UNIT

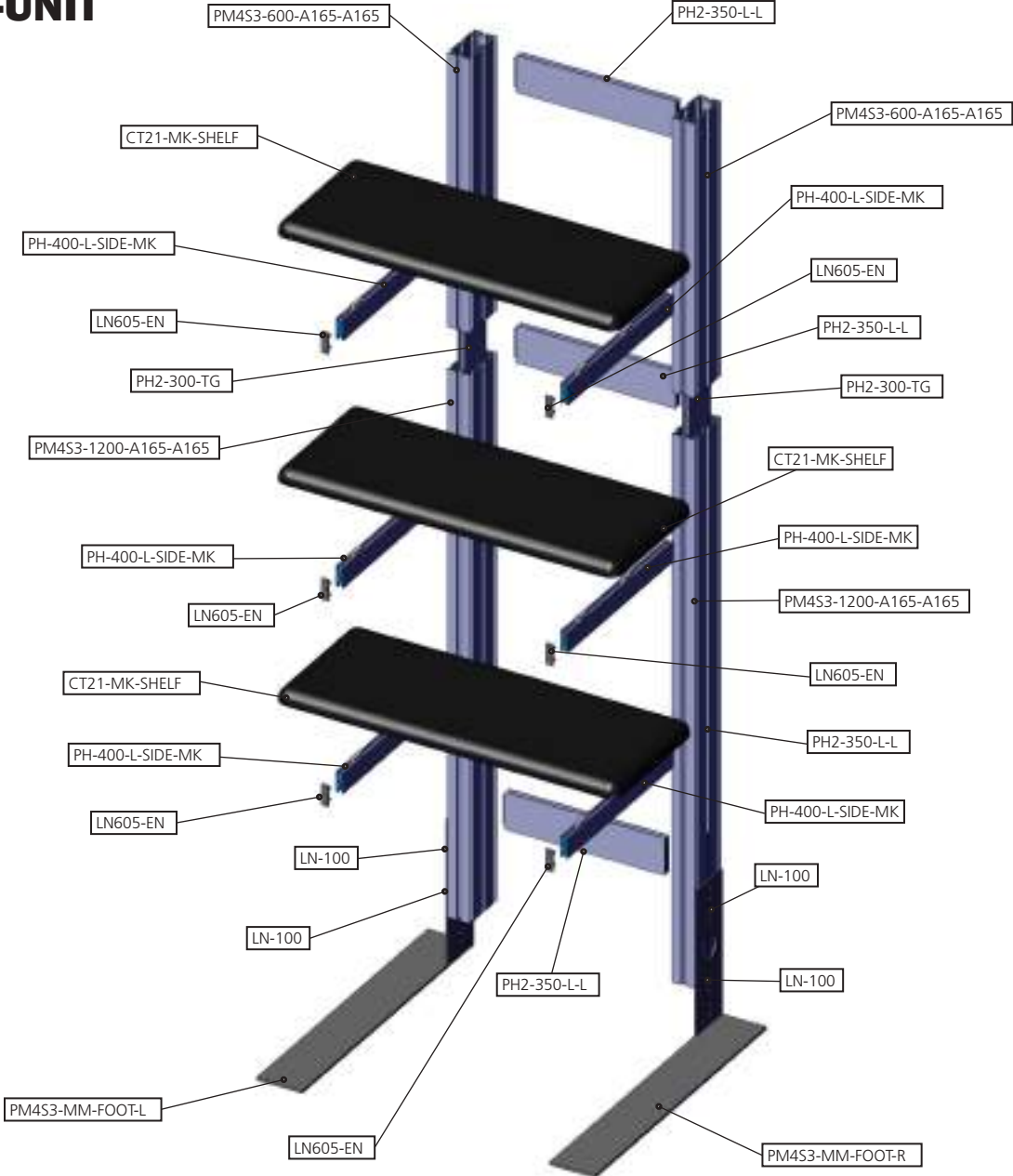

# Kit Assembly

## Step by Step

### Step 1.

Reference the image to the right. Locate the coded extrusions. Slide the PH2-300-TG connector into one end of the PM4S3-1200-A165-A165 so that it goes as deep as the internal pins. Connect the PM4S3-600-A165-A165 by sliding it over the PH2-300-TG. Repeat for this step for the second vertical.

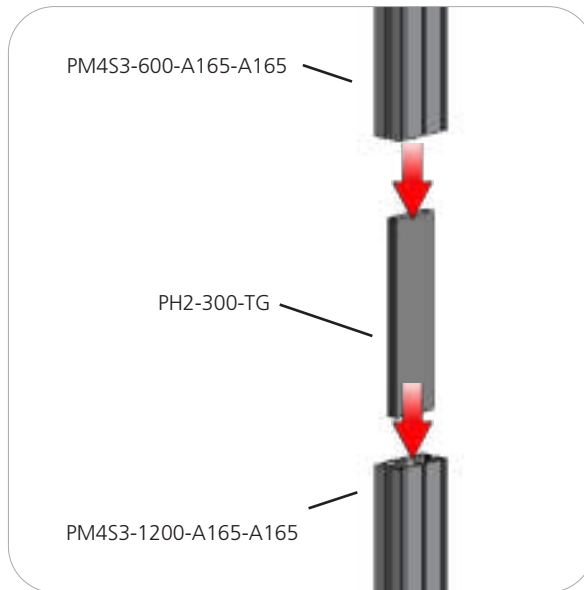

### Step 2.

Collect your extrusions and handtool. Using the provided handtool, lock the extrusions into the back channel of the three channel PM4S3 faces as shown in the image below. Be sure the locks face toward the back of the assembly and do not over tighten.

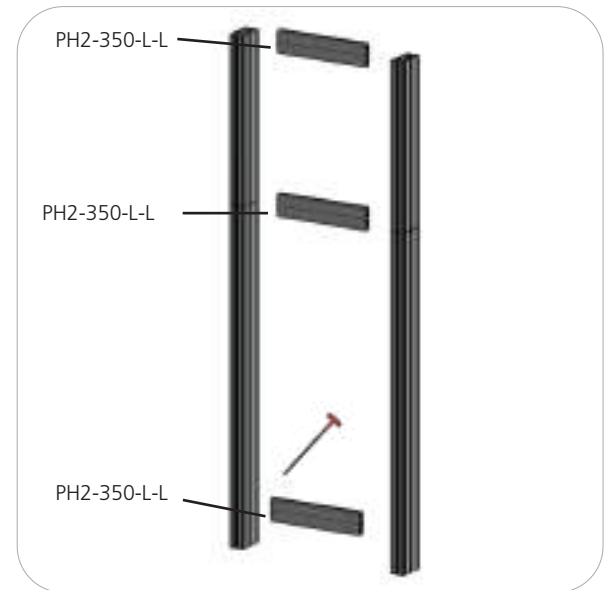

### Step 3.

Locate the M5 thumbscrews, LN100s, and the PM4S3-MM stabilizing bases. Slide the LN100s into the middle channel of the PM4S3. Hand screw the M5 thumbscrews through the base holes and into the LN100 holes. Use the handtool to securely fasten the M5 Thumbscrews. Do not over tighten.

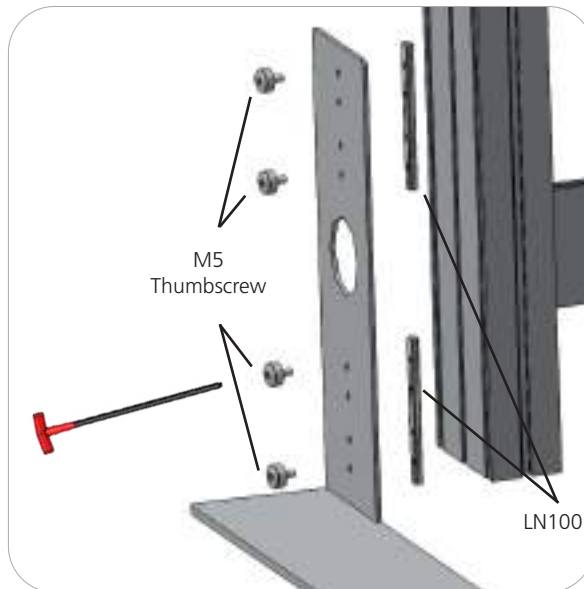

### STOP

Orbus recommends that you move your kiosk(s) in place before continuing on with the rest of assembly.

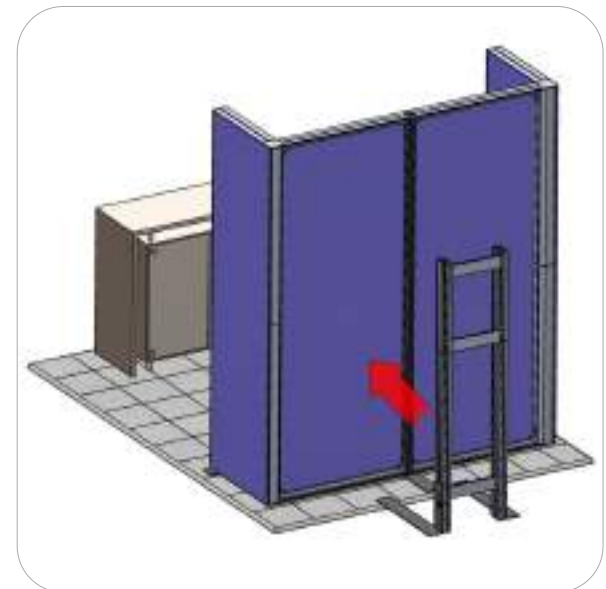

# Kit Assembly

## Step by Step - Monitor Mount

### Step 4.

This step is for kiosks with monitor mounts. Skip to step 7 for shelf kiosks.

Measure from the ground to the center of the hole in your main kit's graphic. Lock the center of your PH5-100-L-L into the PM4S3 stacks at the dimension height of the graphic hole, ADD CBE-50 for support under PH5. Do not over tighten.

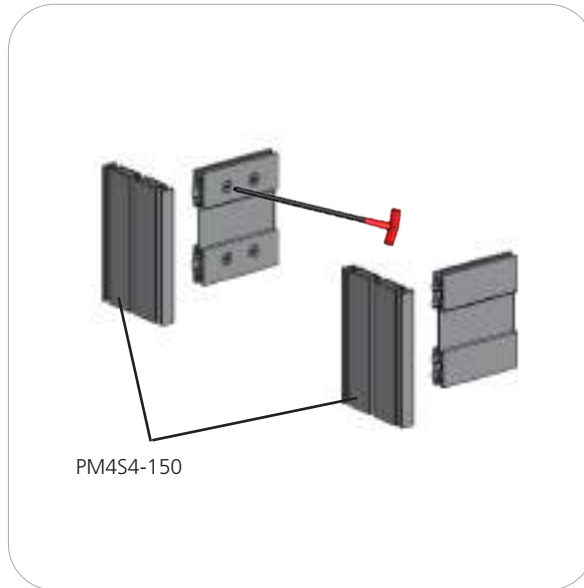

### Step 5.

NOTE: Your main backwall assembly must be completed with graphics before completing this step of the monitor kit.

Lock your PM4S4-150 to the ends of the PH5-100-L-L. Do not over tighten.

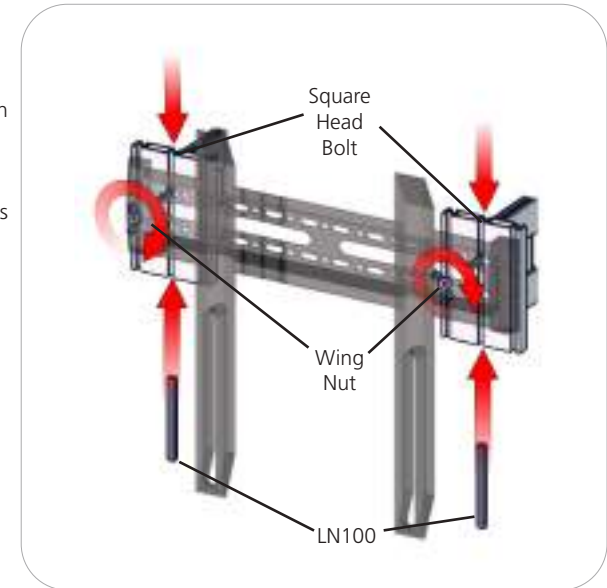

### Step 6.

Set your monitor stand so that the extrusion arms fit through the graphic hole. Use the provided fastening hardware to complete your monitor stand. Slide the LN100 into the bottom center channel of the PM4S4-150. Next, slide the Square Head Bolt into the top center channel of the PM4S4-150. Apply the monitor bracket and spacer washer before fastening with the wingnut. Monitor mount may vary depending on size. Monitor not included.

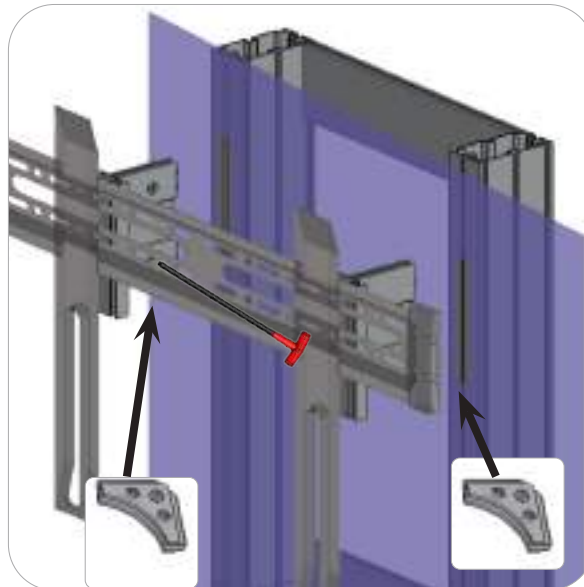

**ATTACH CBE-50 UNDER  
PH5 FOR SUPPORT**

# Kit Assembly

## Step by Step - Shelf

### Step 7.

Insert the LN605-EN end caps. Lock the CT21-MK-SHELF to the PH-400-L-SIDE-MK. Do not over tighten.

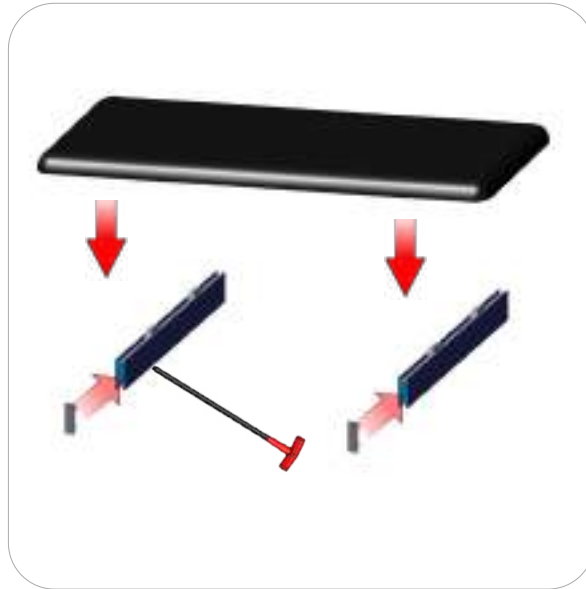

### Step 8.

Lock your PH-400-L-SIDE-MK into the PM453 stacks at the desired dimension height. Do not over tighten.

Refer to the attached supplemental sheet for details on shelf height(s).

Setup is complete.

Repeat steps 7 and 8 twice more for Shelf Unit.

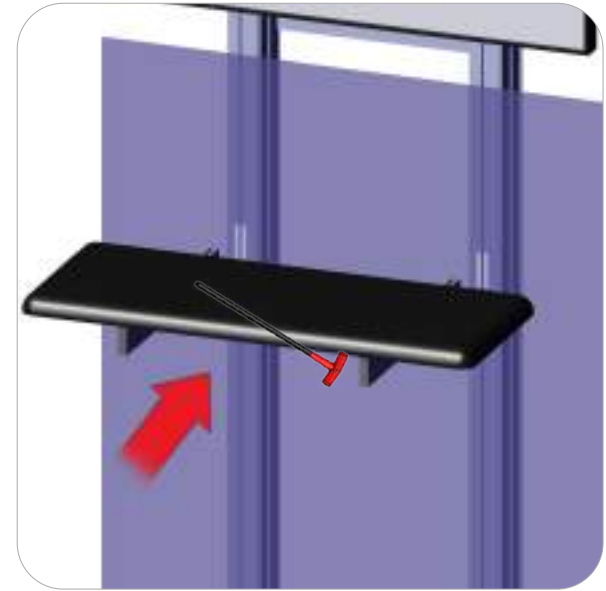

# Freestanding Display Shelf

## PM4S3-MK-SHELF

Freestanding display shelves are easily attached to your assembled kiosk for displaying promotional materials. This shelf can be added to a Freestanding Monitor Kiosk order.



### features and benefits:

- Premium aluminum extrusion frames with cam lock and tension glide assembly
- Easy to store and ship
- Quick to set up
- Lifetime limited hardware warranty against manufacturer defects
- Great for display opportunities

### dimensions:

Hardware	Shipping
<p>Assembled unit: Medium or Large</p> <p>29.53" w x 6.35" h x 15.87" d 751mm(w) x 162mm(h) x 404mm(d)</p> <p>Approximate weight (shelf): 10 lbs / 5 kg</p>	<p>Ships in box</p> <p>Shipping dimensions: Special order - 30"(l) x 16"(h) x 4"(d) 762mm(l) x 407mm(h) x 102mm(d)</p> <p>Approximate total shipping weight: 12 lbs / 6 kg</p>
additional information:	
<p>-Shelf can hold suggested max weight 15 lbs</p> <p>-If shipping with backwall kit cases may vary</p>	

We are continually improving and modifying our product range and reserve the right to vary the specifications without prior notice. All dimensions and weights quoted are approximate and we accept no responsibility for variance. E&OE. See Graphic Templates for graphic bleed specifications.

# Included In Your Freestanding Display Shelf

Components, Connectors & Extrusions



PH-400-L-SIDE-MK x2



PE-1200 x2  
\*will ship preattached to shelf



CT21-MK-SHELF x1



LN605-EN x2



# Exploded View

## PM4S3-MK-SHELF

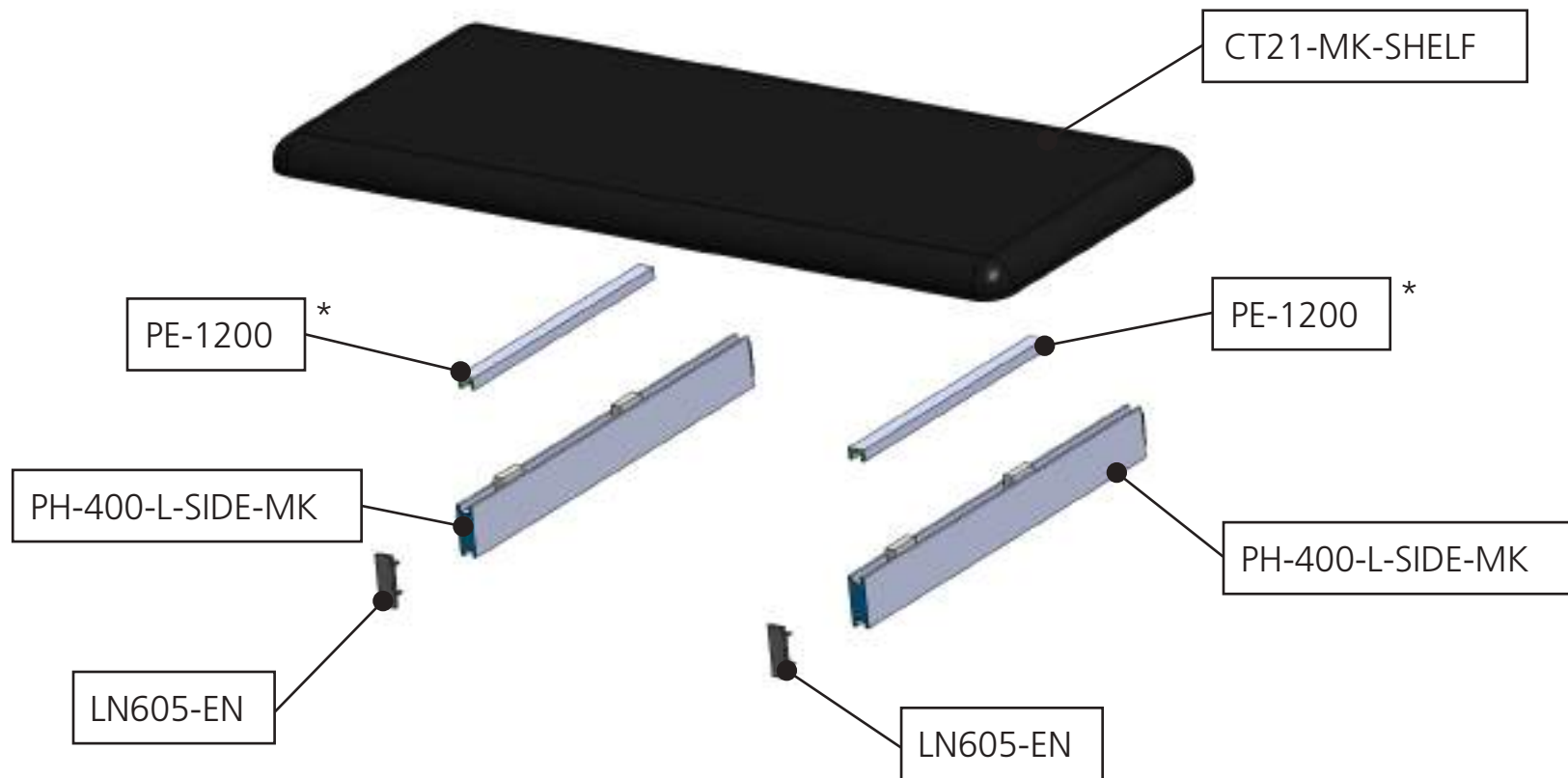

\*Note: PE will ship preattached to shelf

# Kit Assembly

## Step by Step - Shelf

### Step 8.

Insert the LN605-EN end caps. Lock the CT21-MK-SHELF to the PH-400-L-SIDE-MK. Do not over tighten.

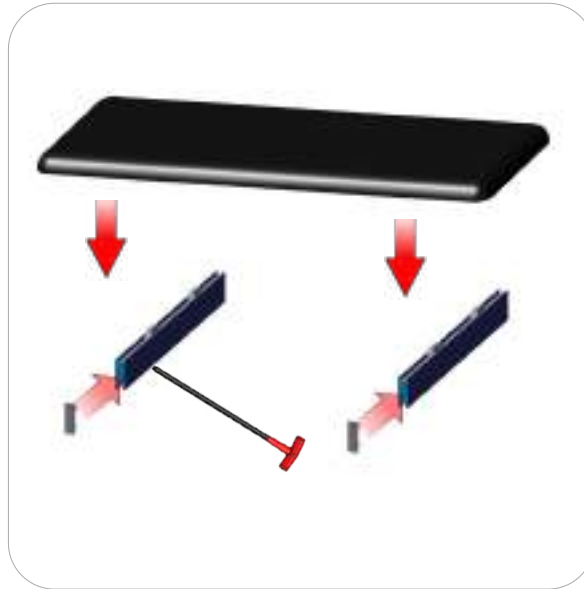

### Step 7.

Lock your PH-400-L-SIDE-MK into the PM453 stacks at the desired dimension height. Do not over tighten.

Refer to the attached supplemental sheet for details on shelf height(s).

Setup is complete.

Repeat steps 7 and 8 twice more for Shelf Unit.

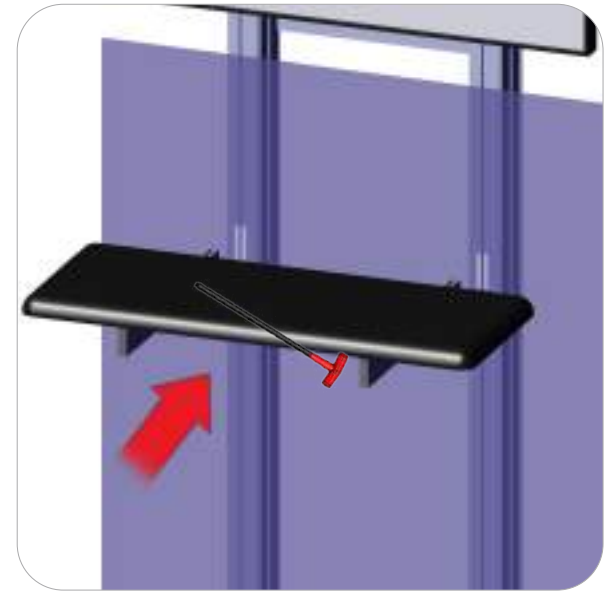



Location of vinyl adhesive tape  
Tape color-**CLEAR**

Indicator shown in green to show detail



**TORQUATA**  
**Self-Adhesive Measuring**  
**Tape**



Note: tape comes preattached to extrusion,  
0" starts from the bottom (at the floor)

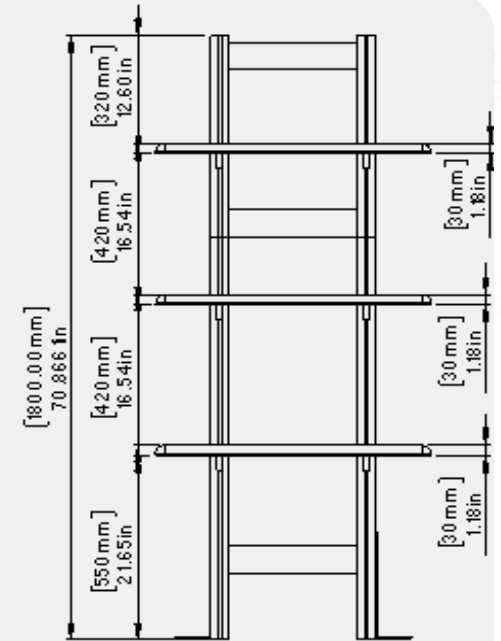
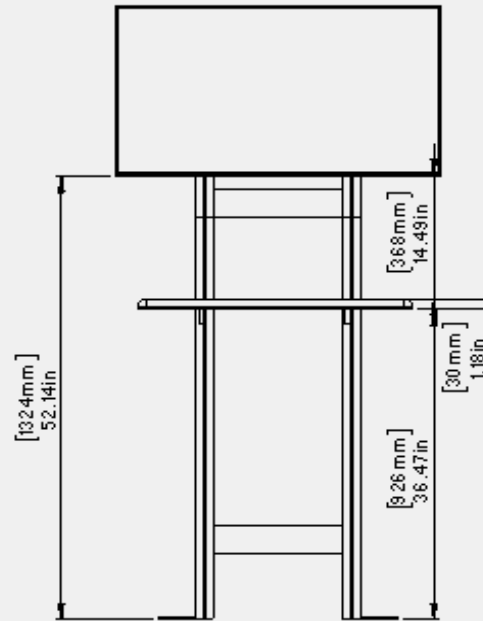
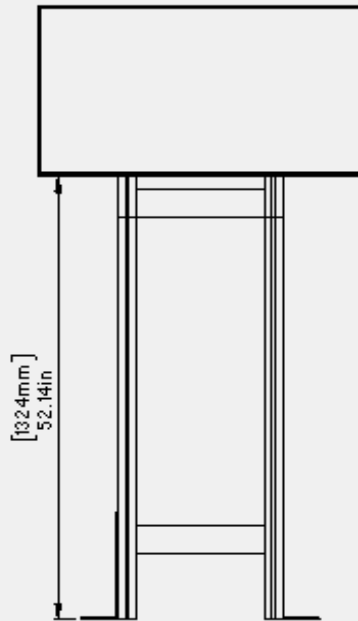

# Hybrid Pro Counter 01-B

## HPC-01-B

All Hybrid Pro™ Modular counters feature accessible storage and locking doors. Purchased magnet applied graphic panel allows for your messaging and branding.



## features and benefits:

- 30mm aluminum stand offs
- Laminated cabinet with locking doors
- Laminated adjustable counter top
- 2 T-handle allen key tools included
- Kit includes an adjustable counter top and one wood crate
- Lifetime hardware warranty against manufacturer defects

## dimensions:

Hardware

Graphic

Assembled unit:  
21.9" w x 38.24" h x 17.72" d  
557mm(w) x 971mm(h) x 450mm(d)

Approximate weight:  
44 lbs / 20 kgs

Refer to related graphic template for more information.

Visit:  
[www.exhibitors-handbook.com/graphic-templates](http://www.exhibitors-handbook.com/graphic-templates)

Shipping

## additional information:

Packing case(s):  
1 HPC-01-B-CRATE

Shipping dimensions:  
48" l x 31" h x 27" d  
1220mm(l) x 787mm(h) x 686mm(d)

Approximate total shipping weight:  
182 lbs / 83 kgs

Recommended tools:  
1/2" hex head wrench keys, not included

### Panel Colors:



grey

black

white



This product may include the following materials for recycle:  
aluminum, select wood, fabric, cardboard, paper, steel, and plastics.

We are continually improving and modifying our product range and reserve the right to vary the specifications without prior notice. All dimensions and weights quoted are approximate and we accept no responsibility for variance. E&OE. See Graphic Templates for graphic bleed specifications.

# Included In Your Kit

Tools, Components, & Connectors



5MM ALLEN-T x1



T-HANDLE-5-32 x1



5/16" - 18 X 2"  
SET SCREWS x9



5/16" - 18 X 2"  
HEX BOLTS x4



CAM LOCK 2010 x4



5/16" - 1 1/4" OD  
FENDER WASHERS x4



TUBE-30-ASY-1 x5



TUBE-30-ASY-2 x4



HPC-01-B-CAB x1

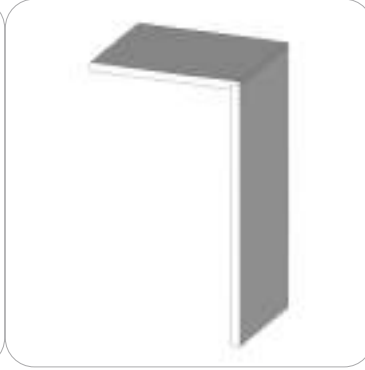

HPC-01-B-CT x1



HPC-01-B-INT x1

# Included In Your Kit

Graphic



HPC-01-B-G x1

# Connection Methods

## Connection Method 1: CAM LOCK



First, with the cam lock disengaged, place the cam lock teeth into the extrusion channel. Second, use the allen key tool to lock it in place. Make half turns clock-wise to engage the cam lock. Do not over tighten the lock buttons.

## Connection Method 2: TUBE-30-ASY-1 / TUBE-30-ASY-2

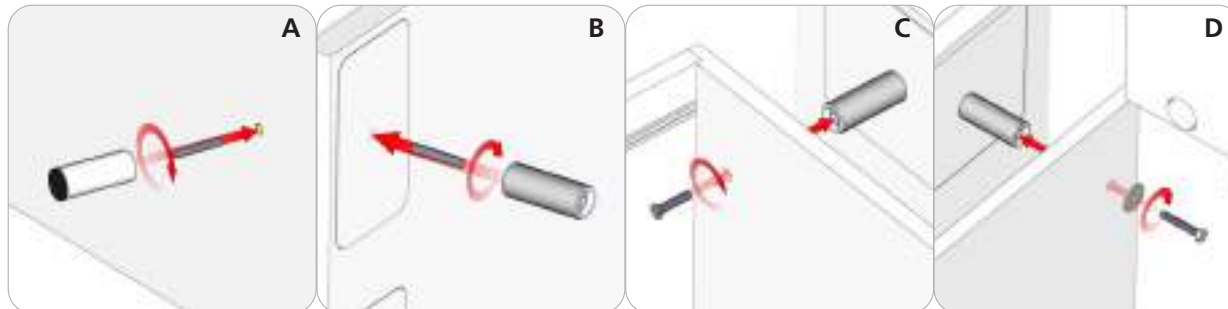

**Image A.** Use the hex key tool to drive the 2" set screw into the panel. Then, hand tighten the 30mm tube assembly 1 onto the set screw.

**Image B.** Use the hex key tool, to drive the 2" set screw into the panel. Then, hand tighten the 30mm tube assembly 2 onto the set screw.

**Image C.** Drive the countersink screws into the 30mm tube assembly 2.

**Image D.** Use a 1/2" hex wrench (tool not included) to drive the hex bolt and washer into the 30mm tube assembly 2.

# Kit Assembly

## Step by Step

### Step 1.

Use the provided hex key tool for attaching the 4 set screws. Make sure the set screws are flush to the inside surface and do not protrude into the cabinet. Next, hand tighten the 30mm tube feet onto the set screws.

Reference Connection Method 3 Image A for more details.

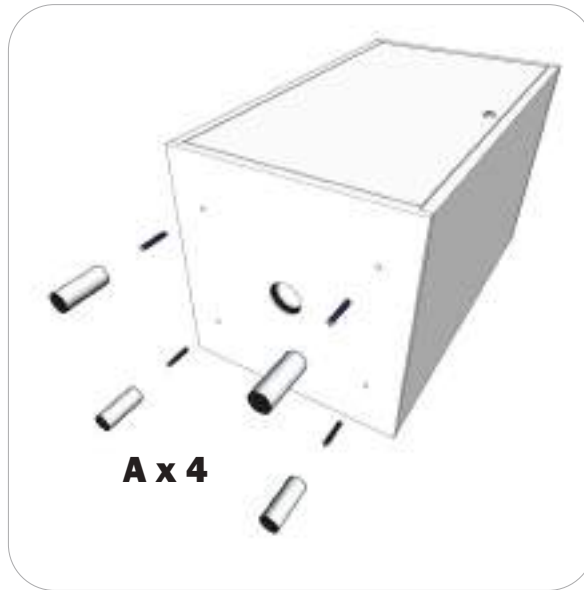

### Step 2.

Use the provided hex key tool for attaching the 5 set screws to the counter top. Next, hand tighten the 30mm tube posts onto the set screws.

Reference Connection Method 3 Image A and B for more details.



### Step 3.

Use a 1/2" hex wrench (tools not included) for attaching the four 30mm tube posts of the countertop onto the cabinet.

Reference Connection Method 3 Image D for more details.

This counter top can be assembled on the left or right.



### Step 4.

Using the provided allen key tool, attach the 4 camlocks into the cabinets inside extrusion channels. Make sure they are all at the same height and level for the internal shelf.

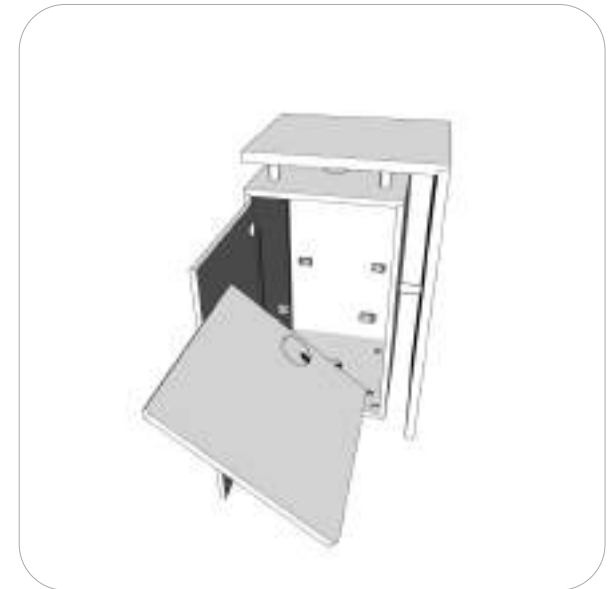

# Kit Assembly

## Step by Step

### Step 5.

Attach UV printed graphic, adhesive backed vinyl to door.

